

3000 POCKET DOOR TECHNICAL DATA

KWIK-WALL... One Source for Wall Systems.

KWIK-WALL's Pocket Doors for the 3000 Series - Steel Panel operable wall systems answer the challenge for space division needs posed by multi-purpose room layouts. Years of continuing research and development have produced many outstanding features!

KWIK-WALL offers a full complement of Pocket Doors for customizing any 3000 Series Steel Panel operable wall system to meet the specific needs of the most demanding project. STC of Pocket Door panels will match the STC of the Operable Wall specified.

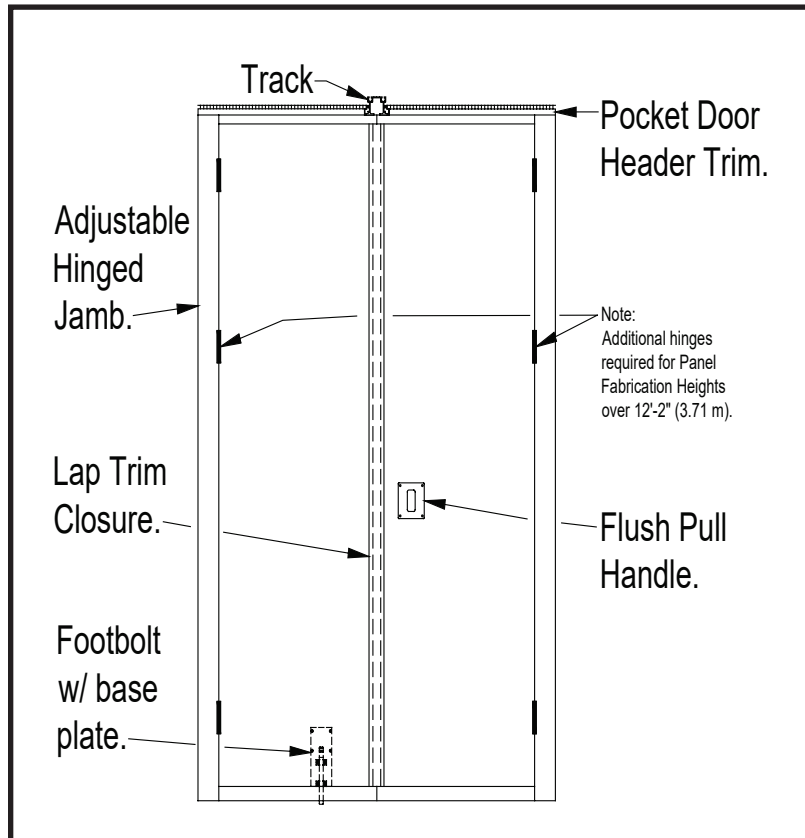



1.01 WORK INCLUDED

- A. Pocket Door(s) shall be furnished, installed and serviced by KWIK-WALL's authorized distributor, in compliance with the architectural drawings and specifications contained herein.

1.02 RELATED WORK

- A. Insulation: Sound insulation and baffles for the plenum area above the pocket door(s), under the permanent floor, inside air ducts passing over or around the pocket door(s), and in permanent walls adjoining the pocket door(s) shall be by others, in accordance with ASTM E 557.
- B. Opening Preparation: Proper and complete preparation of the pocket door opening shall be by others in accordance with ASTM E 557, and shall include floor leveling; plumbness of adjoining permanent walls; substrate and / or ceiling tile enclosures and the painting and finishing of trim and other materials adjoining the head and jamb areas of the pocket door(s). Any permanent wall(s) receiving an adjustable hinged jamb will require internal structural blocking in order to secure the jamb to the permanent wall. Refer to a copy of the shop drawings for additional details.

1.03 SYSTEM DESCRIPTION

- A. The pocket door(s) shall consist of Individual Panel(s) or two (2) panels hinged together that are manually operated and hinged permanently and directly to a structural wall surface.
- B. The pocket door(s) shall consist of acoustically rated panels constructed of the same panel construction as the operable wall system.

1.04 QUALITY ASSURANCE

- A. The pocket door(s) panel construction and finish materials shall consist of Class A rated materials (except as noted, under "Finishes" Part 2 – Products) in accordance with ASTM E84.
- B. The pocket door(s) shall be installed by KWIK-WALL's authorized distributor in accordance with ASTM E 557.

1.05 REFERENCES

- A. ASTM E 557: Architectural Application and Installation of Operable Partitions.
- B. ASTM E 84: Surface Burning Characteristics of Building Materials.
- C. ASTM A 653: Specification for General Requirements for Steel Sheet, Alloy-Coated (Galvannealed) by the Hot Dip Process.
- D. ASTM C 423: Standard Test Method for Sound Absorption and Sound Absorption Coefficients by the Reverberation Room Method.
- E. CCC-W-408A: Federal Specification which applies to Vinyl Coated Wall Coverings.
- F. CFFA-W-101-D: Chemical Fabrics and Film Association Quality Standard for Vinyl Coated Fabric Wall Coverings.

1.06 SUBMITTALS

- A. KWIK-WALL shall provide written technical information and related detail drawings, which demonstrate that the products comply with contract documents for each type of pocket door(s) specified.
- B. KWIK-WALL shall provide detailed engineering drawings featuring panel elevation, horizontal and vertical details as required.
- C. KWIK-WALL shall provide written instructions specifying the proper operation and maintenance of the pocket door(s) system.
- D. KWIK-WALL shall provide a color selector demonstrating the manufacturer's selections of the specified finish material. Samples shall consist of actual swatches of the specified finish material.

1.07 DELIVERY, STORAGE AND HANDLING

- A. Pocket Door(s) shall be individually wrapped in a protective plastic covering to keep panels clean during delivery, storage and handling.
- B. Pocket Door(s) shall be stored on edge and above the floor on cushioned blocking in a dry and ventilated area, protected from humidity and temperature extremes.

1.08 SEQUENCING / SCHEDULING

- A. Pocket Door(s) Installation: Pocket Door(s) installation shall occur after fixed wall substrate construction is properly and completely installed by others, as required to protect panels from ongoing adjacent construction.

1.09 WARRANTY

- A. KWIK-WALL shall warrant each operable wall panel and its component parts to be free from defects in material and workmanship for a period of five (5) years from the date of delivery to the original purchaser, when installed by an authorized KWIK-WALL distributor. KWIK-WALL also warrants the fixed top seals, track, carriers, and its component parts to be free from defects in material and workmanship for a period of ten (10) years. (see actual warranty on Page 12 for details and limitations).



2.01 ACCEPTABLE MANUFACTURER

A. Pocket Doors shall be Series 3000 as manufactured by KWIK-WALL Company.

2.02 PANEL CONSTRUCTION

A. Panel Dimensions: Standard panel dimension shall be a nominal 4" [10.16] thick.

B. Panel Frame: Steel frame shall be 16-gauge galvaneal steel, which meets or exceeds ASTM A 653 requirements. Frame shall be all-welded construction with steel corner supports and cross-bracing reinforcement. Panel frame shall be Class A rated, fire retardant, non-combustible and non-corrosive in accordance with ASTM E 84.

C. Panel Skins: Panel skins shall be Class A rated (except Wood Veneer and High Pressure laminate) in accordance with ASTM E 84. Panel skin material shall consist of (select):

1. Standard Steel Skins: consisting of minimum 22-gauge tension-leveled galvaneal steel, pressure laminated to a structural acoustical backer and mechanically-joined to the steel frame to form a rigid, unitized and structural panel.

2. Optional Acoustical Substrate: consisting of structural acoustical substrate pressure laminated to both sides of the steel frame to form a rigid, unitized and structural panel.

3. Optional Wood Veneer: consisting of particle board core covered with wood veneer and pressure laminated to both sides of the steel frame to form a rigid, unitized and structural panel.

4. Optional High Pressure Laminate: consisting of gypsum board core covered with general purpose plastic laminate and Phenolic backer sheet, which is pressure laminated to both sides of the steel frame to form a rigid, unitized and structural panel.

D. Panel Hinges: Panel hinges shall be architectural grade, full leaf butt hinges. Hinges shall be attached to steel frame utilizing a steel mounting bracket welded to frame.

E. Panel Weight: Maximum panel weight shall be 5.9 – 12.9 lb. / ft.² (29 – 63 kg / m²) depending on size and options selected.

2.03 OPERATION

A. Operation shall consist of an individual panel or panels hinged together in groups of two (2) and hinged to an adjustable jamb. Pocket doors shall be manually operated and capable of swinging 180° to allow sufficient clearance for the operable wall panels. One (1) pocket door panel shall contain a flush pull handle and surface mounted footbolt with strike plate.

2.04 FINISHES

A. Finish Material Type: Pocket Door finish material shall be Class A (except wood veneer and High Pressure laminate) rated in accordance with ASTM E 84, consisting of (select):

1. Vinyl: consisting of Type II, reinforced vinyl weighing 21 oz./lin. yd. (651 g/lin. m). Vinyl shall meet or exceed CCC-W-408A and CFFA-W-101-D quality standards.

2. Optional Upgrade Fabric: consisting of fade and tear resistant fabric that resists water-based stains weighing 13 oz./lin. yd. (403 g/lin. m).

3. Optional Basics Carpet: consisting of acoustically absorbent, non-woven needle punch fibers fused to prevent fraying and unraveling of material weighing 28.5 oz. / lin. yd. (884 g / lin. m). Basics Carpet shall achieve a minimum NRC (Noise Reduction Coefficient) rating of .20 (applied over gypsum substrate) in accordance with ASTM C 423.

4. Optional Upgrade Carpet: consisting of acoustically absorbent, non-woven needle punch fibers fused to prevent fraying and unraveling of material weighing 23 oz. / lin. yd. (713 g / lin. m). Upgrade Carpet shall achieve a minimum NRC (Noise Reduction Coefficient) rating of .25 (applied over gypsum substrate) in accordance with ASTM C 423.

5. Optional Wood Veneer: consisting of unfinished flat cut wood veneer laminated to 1/2" [12.7] thick particle board core. Veneer shall be book / running matched within a panel, and vertically edge banded if Trimless astragals are specified.

(Note: Optional Class "A" rated particle board is available. Acoustical substrate STC ratings apply for Wood Veneer panel construction.)

6. Optional High Pressure Laminate: consisting of gypsum board core covered with general purpose plastic laminate and Phenolic backer sheet, which is pressure laminated to both sides of the steel frame to form a rigid, unitized and structural panel.

(Note: Acoustical substrate STC ratings apply for High Pressure Laminate panel construction.)

C. Finish Material Application: Finish material shall be (select):

1. Standard Factory Applied: by operable wall manufacturer. Customer supplied finish material samples must be submitted to manufacturer for testing and approval prior to acceptance and application.

2. Optional Field Applied: by others.

3000 SERIES POCKET DOOR PRODUCT GUIDE Standard Steel Skin Construction

Panel Thickness (nominal)	Max. Panel Weight lb./ft. ²	Max. Pocket Door Height
4" [10.16]	8.5 (41 kg/m ²)	24' - 2" (7.37 m)
4" [10.16]	9.5 (46 kg/m ²)	22' - 2" (6.76 m)
4" [10.16]	12.9 (63 kg/m ²)	16' - 2" (4.93 m)

*Optional Wood Veneer or High Pressure Laminate only available as Acoustical Substrate Construction.

3000 SERIES POCKET DOOR PRODUCT GUIDE Optional Acoustical Substrate Construction

Panel Thickness (nominal)	Max. Panel Weight lb./ft. ²	Max. Pocket Door Height
4" [10.16]	5.9 (29 kg/m ²)	14'-2" (4.32 m)
4" [10.16]	6.6 (32 kg/m ²)	14'-2" (4.32 m)
4" [10.16]	7.5 (37 kg/m ²)	14'-2" (4.32 m)
4" [10.16]	9.0 (44 kg/m ²)	14'-2" (4.32 m)

*KWIK-WALL recommends fabricating pocket door(s) to the same Maximum Panel Weight as the operable wall system.

2.06 PERIMETER TRIM AND SEALS

A. Vertical Trim and Seals: Panels shall have vertical astragals containing flexible vinyl seals and incorporate reversible tongue-and-groove-type configurations for positive interlocking with adjacent panels. Vertical astragal type shall be (select):

1. Standard Trimless Astragal: consisting of an aluminum extrusion with tongue-and-groove-type vertical astragals. Vertical trim shall not be permitted on the panel faces, resulting in a minimal groove appearance between adjacent panels.
2. Optional Cap-type Astragal: consisting of an aluminum extrusion with tongue-and groove-type vertical astragals for encapsulating and protecting the finish material and substrate along the vertical edge of the panel.

Note: Optional Cap-type Astragal is not available for Model 3050 Electrically Operated Walls.

B. Horizontal Top Trim and Seals: Top seals shall consist of flexible vinyl sweep seals installed on both sides of the panel. The seals shall consist of a compressed bulb between two (2) fingers of vinyl. Top seal type shall be Fixed consisting of continuous-contact flexible vinyl, sealing against the pocket door header trim.

C. Horizontal Bottom Trim and Seals: Bottom seals shall consist of a flexible vinyl sweep seal installed on both sides of the panel. Seal shall consist of a single finger of vinyl. Bottom seal type shall be Fixed consisting of continuous-contact flexible vinyl, sealing against various floor surfaces.

D. Pocket Door Header Trim: Header trim shall be extruded from aluminum alloy, which prohibits deterioration caused by rust or corrosion. The header trim shall have a durable E.S.P. Bronze finish. Header Trim shall be attached to the finished ceiling directly above the pocket door(s), providing a flush surface for the Fixed top seals to contact.

E. Horizontal and Vertical Panel Trim: All exposed panel trim and hinges shall be of one (1) similar color (select):

1. Dark Bronze.
2. Grey.

2.07 POCKET DOOR CLOSURES

A. Pocket Door Types: Each pocket door configuration shall be hinged to an adjustable jamb consisting of an aluminum extrusion which is permanently mounted to a structural wall surface and is field-adjustable to compensate for out-of-plumb conditions of the fixed wall. The adjustable jamb shall incorporate a tongue-and-groove-type vertical astragal for positive interlocking with a pocket door panel. To stabilize the pocket door(s) a surface mounted foot bolt shall be furnished by the operable wall manufacturer and installed by others in the field. The pocket door configuration shall be (select):

1. Bi-Fold Doors w/ Bulb Seal: consisting of a pair of panels hinged together and hinged to an adjustable jamb. The lead panel shall contain flexible vinyl bulb seals installed along the vertical edge of the lead panel for positive compression against a rigid wall surface. A roller support caster located at the bottom of one (1) panel shall be included to provide additional support for the pocket doors.

Note: This type of pocket door is normally used with a Model 3020 or 3020WT operable wall system utilizing a perpendicular stack unit.

2. Single Door w/ Bulb Seal: consisting of a single panel hinged to an adjustable jamb. The lead edge of the panel shall contain flexible vinyl bulb seals installed along the vertical edge creating a positive compression against a rigid wall surface.

Note: This type of pocket door is normally used with a Model 3020 or 3020WT operable wall system utilizing a parallel or remote stack unit.

3. Single Door w/ Expander: consisting of a single panel hinged to an adjustable jamb. The lead edge of the panel shall contain an expander mechanism with a nominal 5" [127] of travel, activated from the face of the panel using a removable wrench as supplied by manufacturer.

Note: This type of pocket door is normally used with a Model 3020 or 3020WT operable wall system utilizing a parallel or remote stack unit.

4. Double Doors w/ Lap Trim: consisting of two (2) individual panels with each panel being hinged to an adjustable jamb. The lead edge of each panel shall contain a lap type extrusion that overlaps with the other one, creating a shiplap joint.

Note: This type of pocket door is normally used with a Model 3030 operable wall system utilizing a center type stack arrangement or Model 3020 or 3020WT remote stack unit.

5. Double Doors w/ Expander: consisting of two (2) individual panels with each panel being hinged to an adjustable jamb. The lead edge of one (1) panel shall contain an expander mechanism with a nominal 5" [127] of travel, activated from the face of the panel using a removable wrench as supplied by manufacturer. The lead edge of the adjacent panel shall contain flexible vinyl bulb seals installed along the vertical edge for positive compression against the face of the operable wall panel.

Note: This type of pocket door is normally used with a Model 3030 operable wall system utilizing a center type stack arrangement.

6. Double Doors w/Expander and Interlock Switches: consisting of two (2) individual panels with each panel being hinged to an adjustable jamb. The lead edge of one (1) panel shall contain an expander mechanism with a nominal 5" [127] of travel, activated from the face of the panel using a removable wrenches supplied by manufacturer. The lead edge of the adjacent panel shall contain flexible vinyl bulb seals installed along the vertical edge for positive compression against the face of the operable wall panel. Each pocket door shall contain an electric Interlock Switch to prevent the operator from running until the pocket doors have been opened up 180°.

Note: This type of pocket door is used with Model 3050 electrically operated wall system utilizing a center type stack arrangement.

Note: Pocket doors require additional depth and width to the stack area.



2.08 ACOUSTICAL PERFORMANCE

A. Certification: The pocket door(s) shall be of the same panel construction as the operable wall panels.

2.09 POCKET DOOR ACCESSORY

A. Accessory includes Keyed Cylinder Lock with adjustable concealed vertical rod interfacing with strike plate attached to finished floor. Lock unit shall be capable of receiving a master cylinder, furnished by others and installed by KWIK-WALL as noted on submitted shop drawings.

3.01 INSPECTION

- A. Proper and complete preparation of the pocket door opening shall be by others in accordance with the architectural drawings, KWIK-WALL's shop drawings and ASTM E 557. Any deviation of the actual opening from these specifications shall be called to the attention of the architect prior to the installation of the pocket door(s).
- B. Deficiencies in the pocket door opening shall be corrected by others prior to installation of the pocket door(s).

3.02 INSTALLATION

- A. The pocket door(s) shall be installed by KWIK-WALL's authorized distributor.
- B. The pocket door(s) shall be installed in accordance with KWIK-WALL's written instructions, shop drawings and ASTM E 557 installation guidelines.

3.03 ADJUSTING AND CLEANING

A. The pocket door(s) shall be adjusted and cleaned in accordance with KWIK-WALL's written instructions.

3.04 PROTECTION

A. The pocket door(s) shall be stored in the "extended" position prior to acceptance by the owner's representative.

3.05 DEMONSTRATION

A. KWIK-WALL's authorized distributor shall demonstrate proper operation and explain proper and necessary maintenance requirements of the pocket door(s) to the owner's representative.

3000 SERIES - POCKET DOORS SELECTION CHART

Pocket Door Type	Maximum Pocket Door Opening Width	Panel Fabrication Height**										
		Up to 8' - 2" (2.49 m)	Up to 9' - 2" (2.79 m)	Up to 10' - 2" (3.10 m)	Up to 11' - 2" (3.40 m)	Up to 12' - 2" (3.71 m)	Up to 13' - 2" (4.01 m)	Up to 14' - 2" (4.32 m)	Up to 15' - 2" (4.62 m)	Up to 16' - 2" (4.93 m)	Up to 22' - 2" (6.76 m)	Up to 24' - 2" (7.37 m)
Bi-Fold w/ Bulb Seal	5' - 0" (1.52 m)							NOT AVAILABLE				
Double w/ Expander	6' - 8" (2.03 m)											
Double w/ Lap Trim	6' - 8" (2.03 m)											
Single w/ Bulb Seal	3' - 5" (1.04 m)											
Single w/ Expander	3' - 11" (1.19 m)											

*KWIK-WALL recommends fabricating pocket door(s) to the same Maximum Panel Weight as the operable wall system.

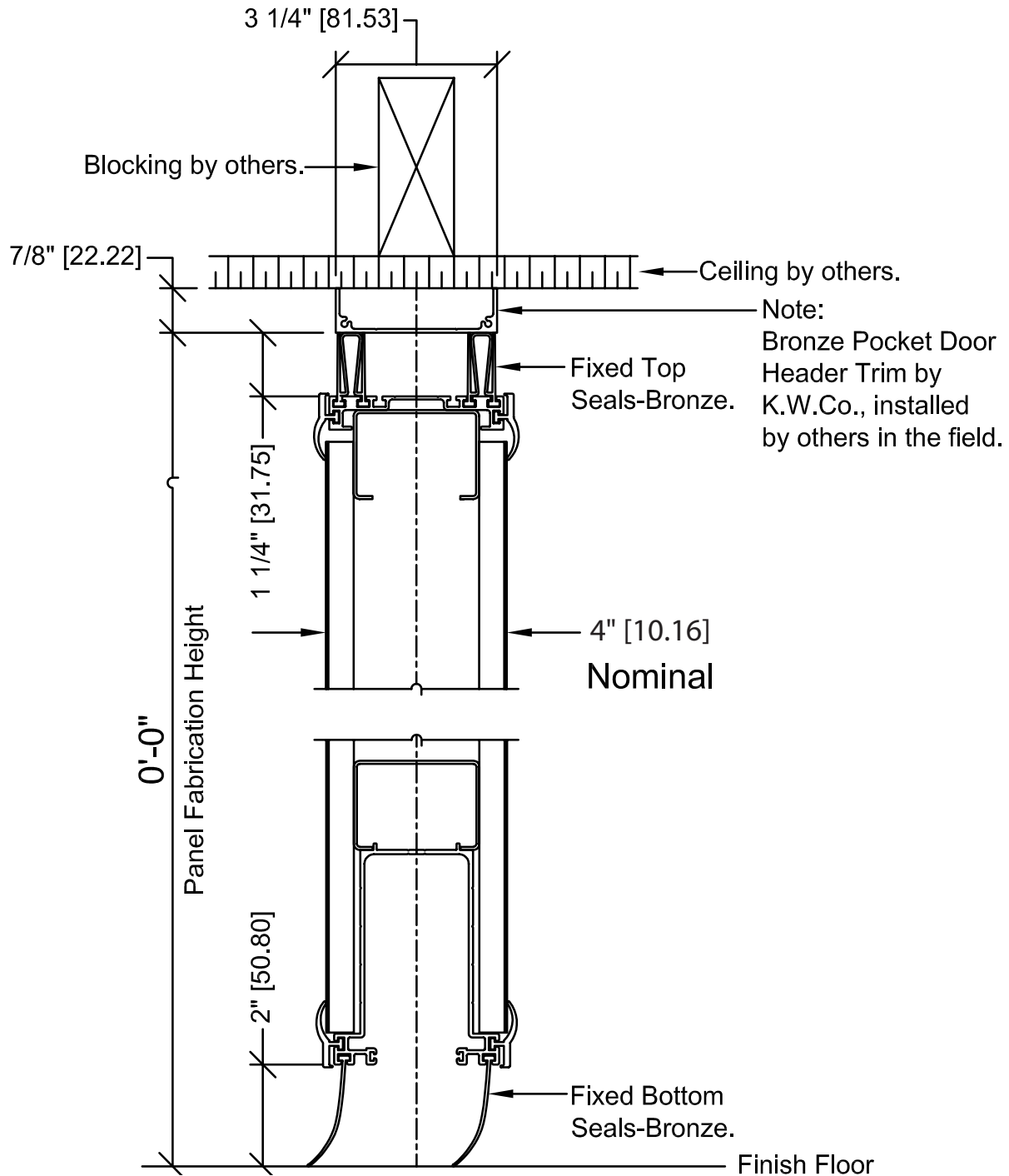

Single or Double Pocket Door

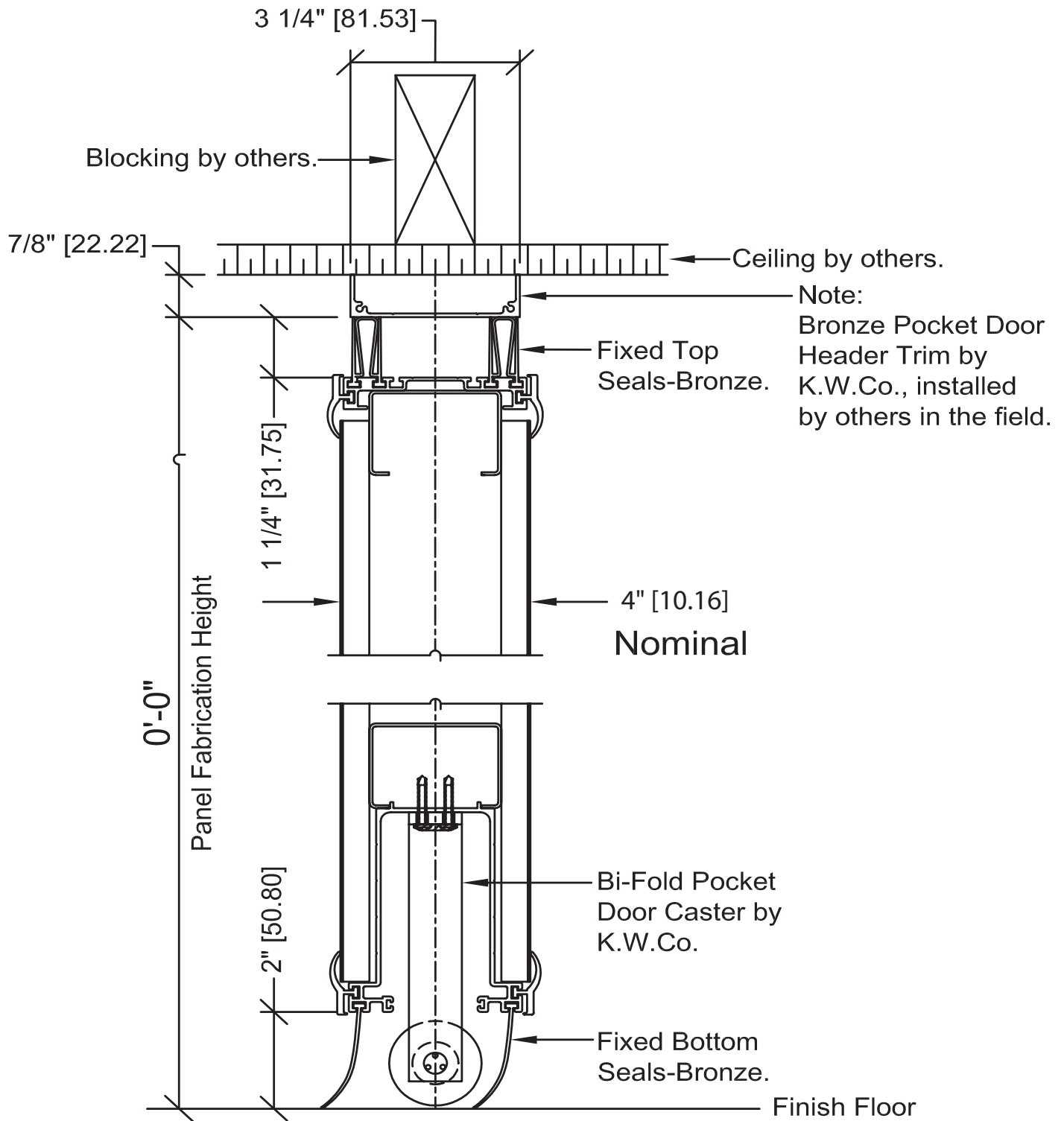

Bi - Fold Pocket Door

Bi-Fold Doors with Bulb Seal

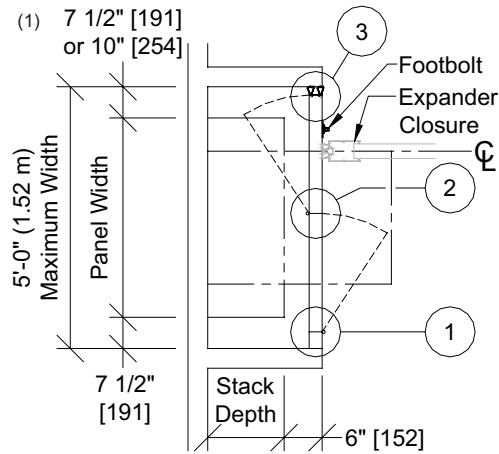

Plan View

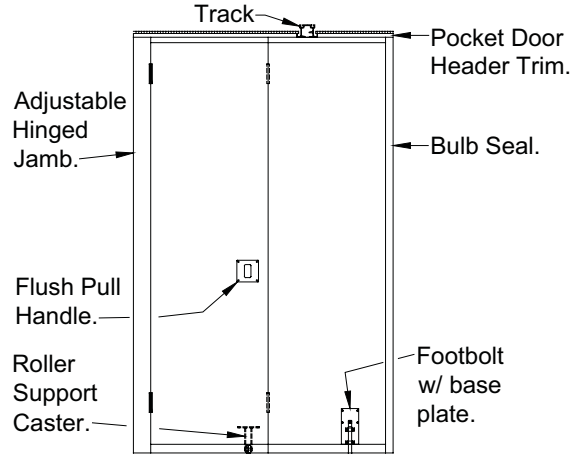

Elevation View

Single Door with Bulb Seal

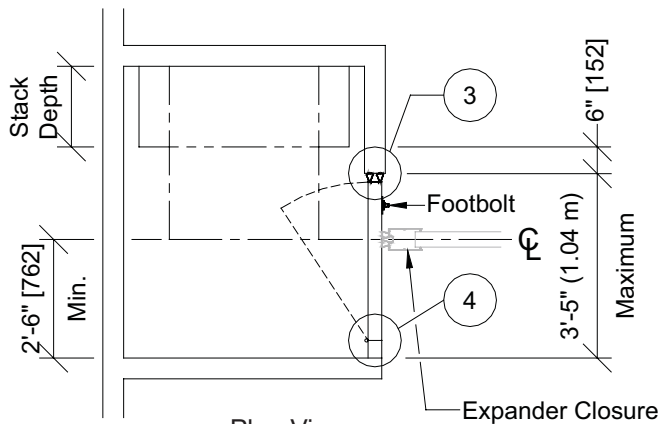

Plan View

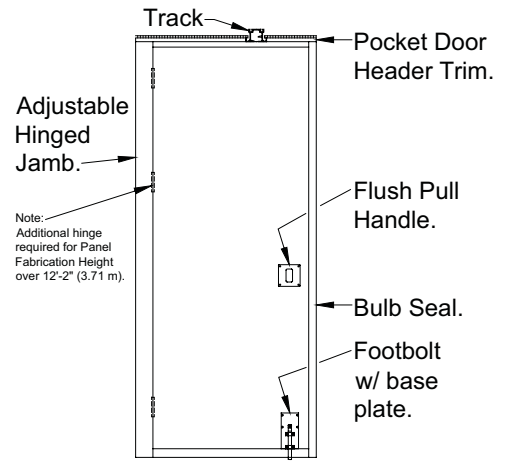

Elevation View

Single Door with Expander

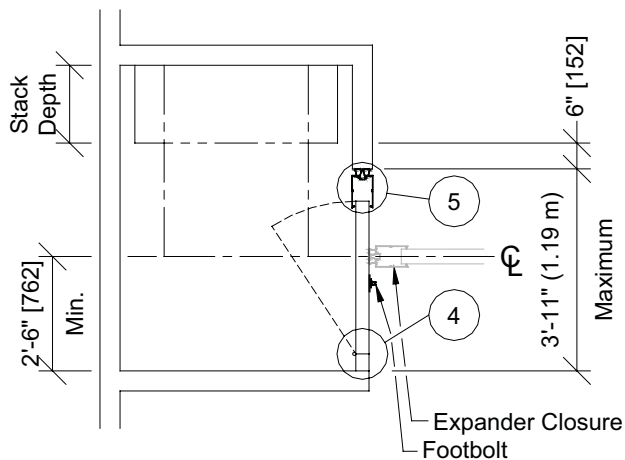

Plan View

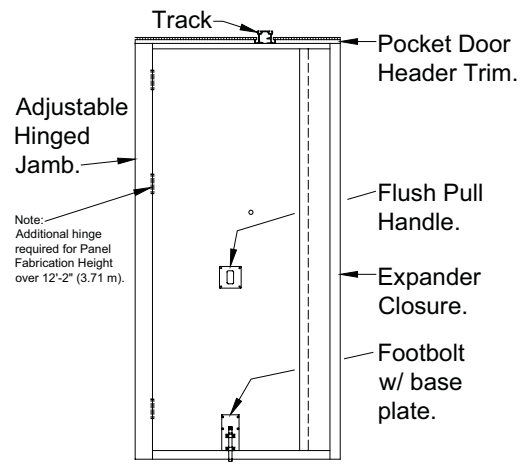

Elevation View

Double Doors with Expander

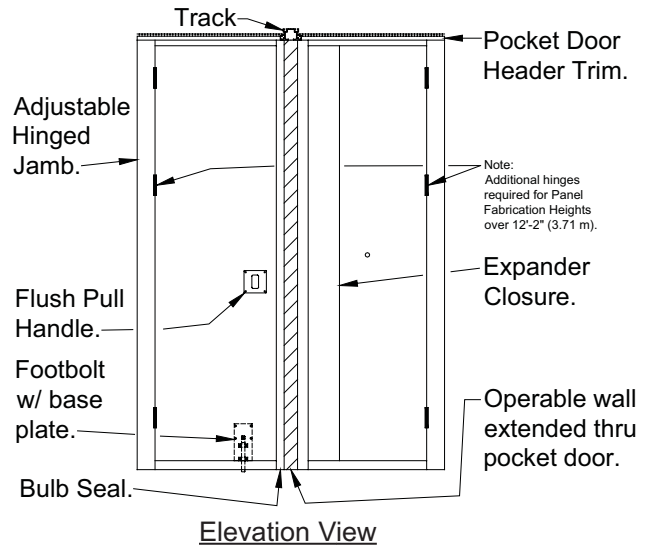
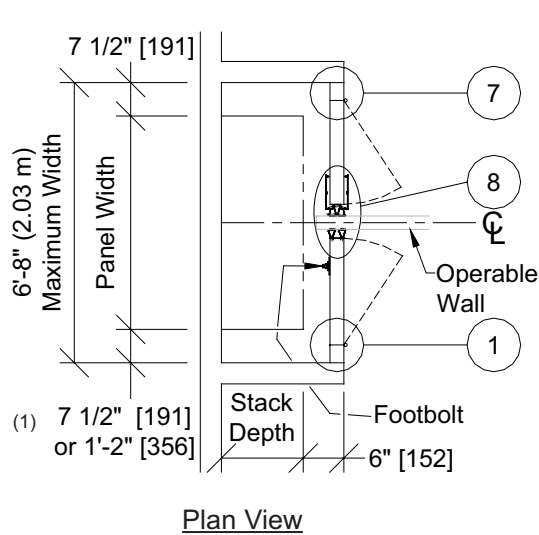

Double Doors with Lap Trim

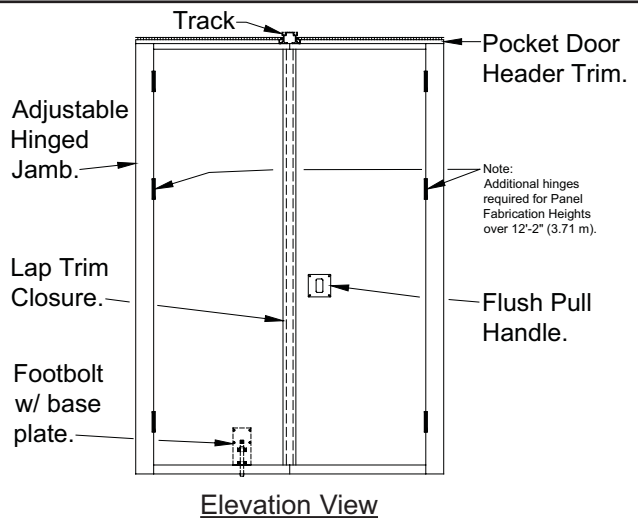
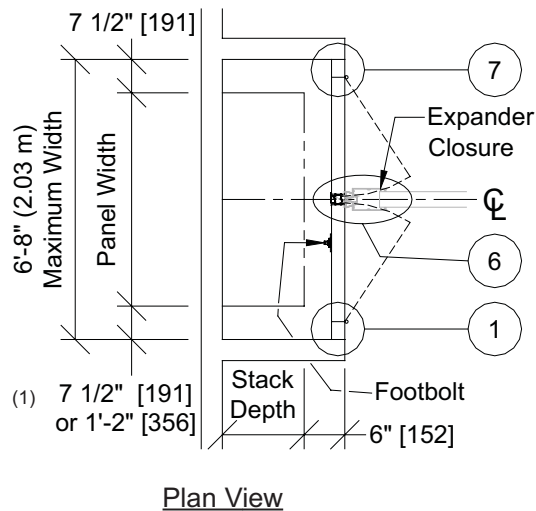

1. Adjustable Hinged Jamb
2. Hinged Joint
3. Bulb Seal
4. Adjustable Hinged Jamb
5. Expander Closure
6. Lap Closure
7. Adjustable Hinged Jamb
8. Expander / Bulb Seal Closure

Horizontal Details for numbers 1 through 8 can be found on page 10 and 11

Notes:

1. Operable wall systems containing automatic bottom seals require additional pocket width.
2. KWIK-WALL has designed five (5) types of pocket doors that work with our operable wall configurations, if your project requires a custom designed pocket door please contact your local distributor.

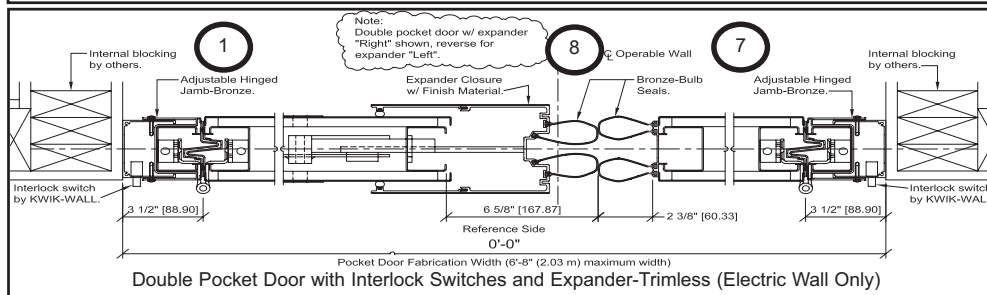
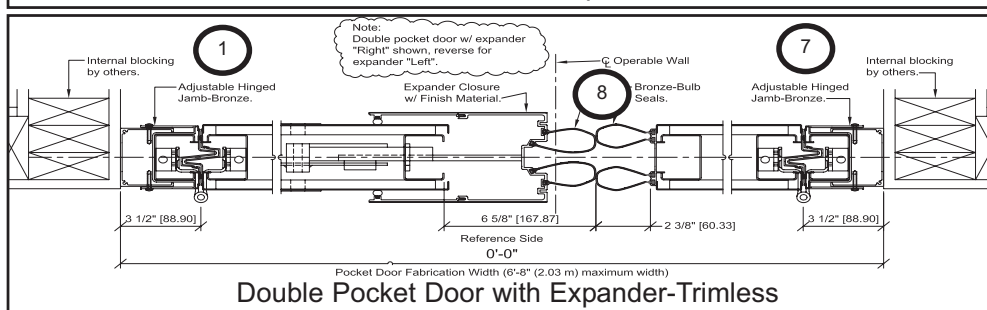
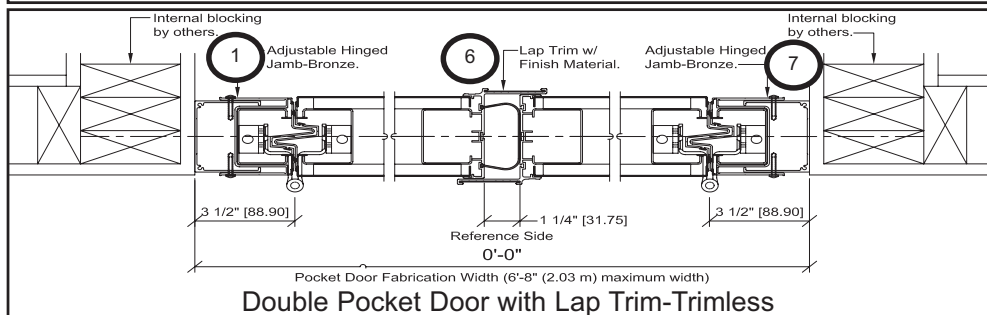
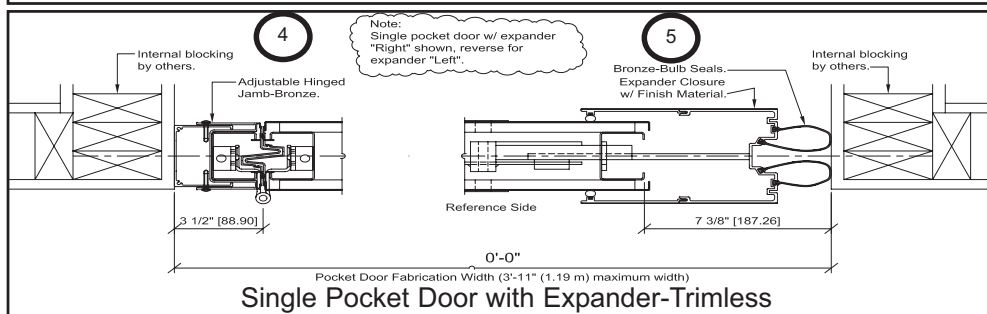
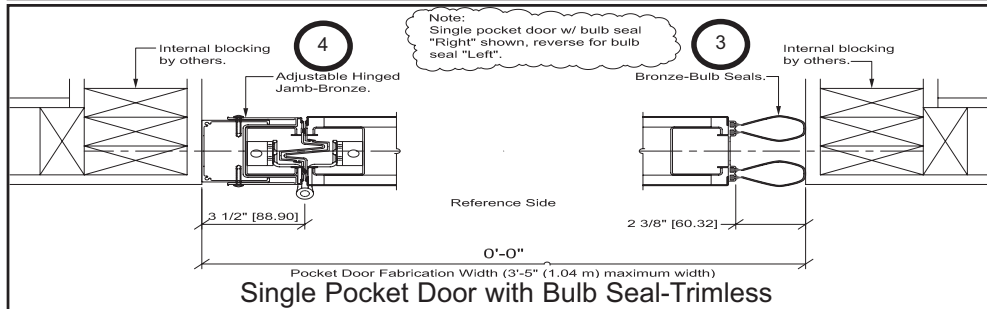
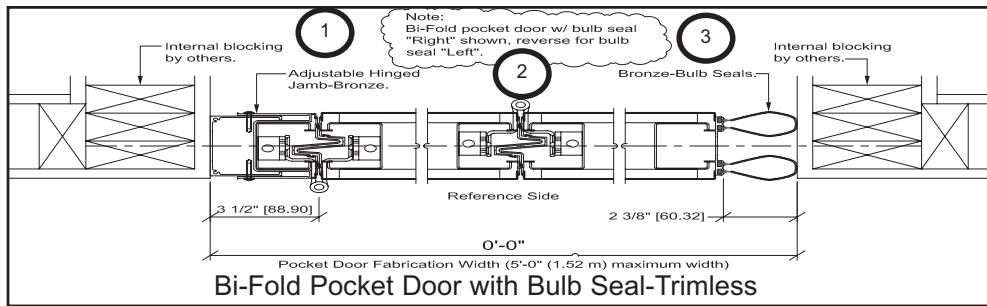

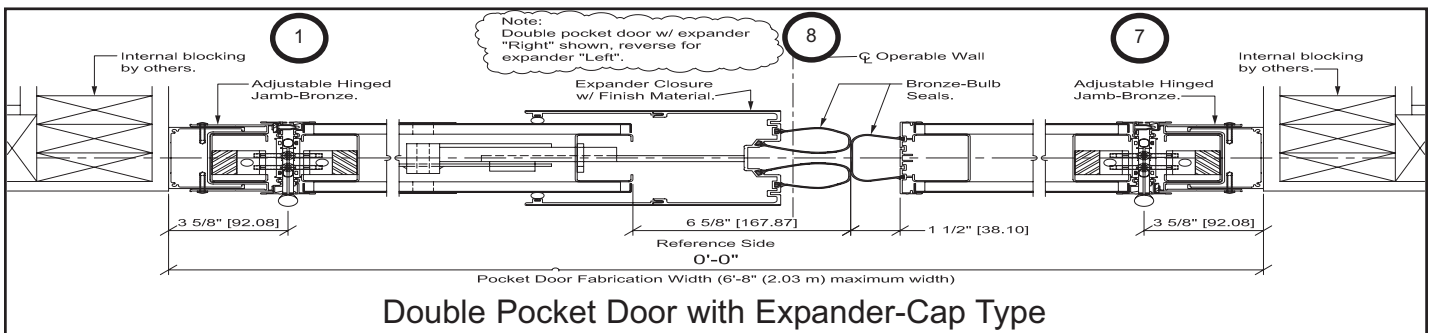
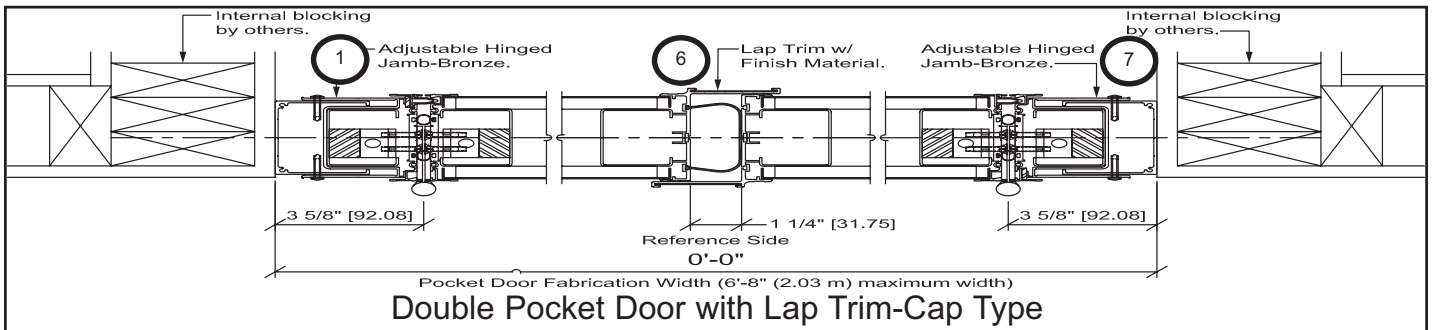
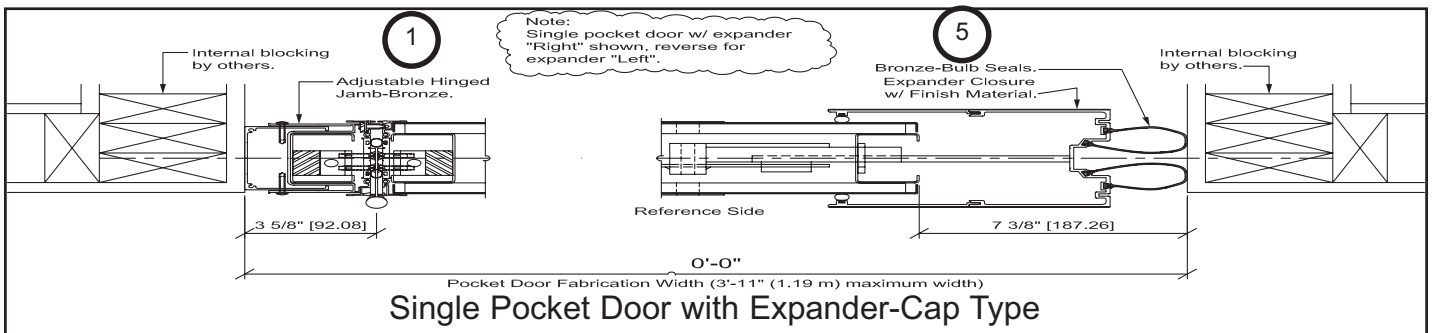
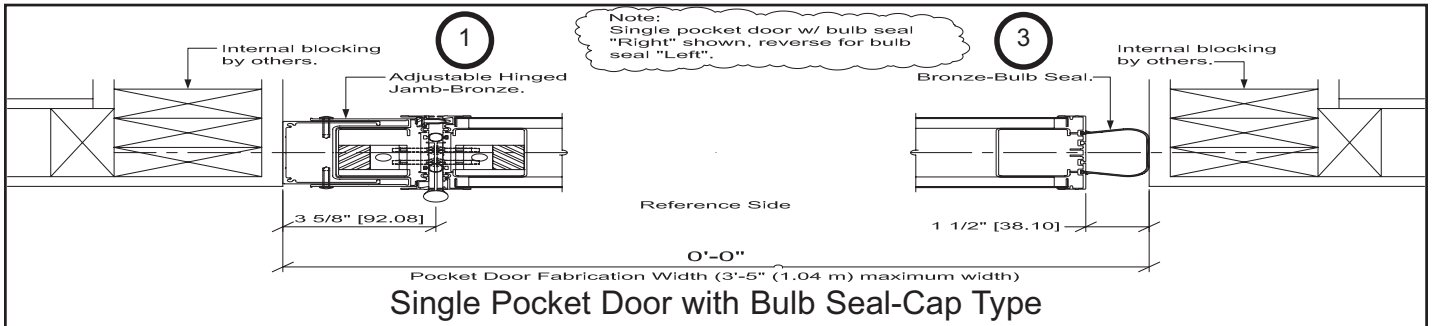
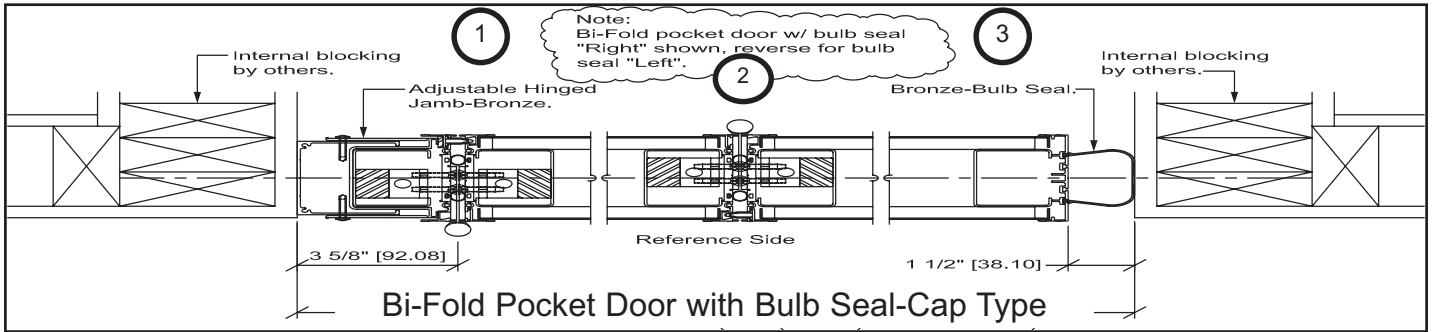

KWIK-WALL Company warrants each operable wall panel and its component parts to be free from defects in material and workmanship for a period of five (5) years from date of delivery to the original purchaser, when installed by an authorized KWIK-WALL distributor. KWIK-WALL also warrants the fixed top seals, track, carriers, and its component parts to be free from defects in material and workmanship for a period of ten (10) years. The Model 3050 electric wall because of its special track and carrier system will continue to carry the standard five (5) year warranty for all components. KWIK-WALL Company reserves the rights to have authorized personnel inspect any part alleged to be defective and to refuse any returned material unless the return was previously authorized by KWIK-WALL.

This warranty does not apply to any damage or deterioration caused by abuse or failure to provide reasonable and necessary maintenance. All field applied finishes, accessories or product modifications are specifically excluded under this warranty. KWIK-WALL's liability hereunder is limited to the replacement of any panel or component part found to be defective. Labor charges are the responsibility of the customer.

In order to keep the warranty valid, routine maintenance must be performed in accordance with manufacturer's specifications on the operable wall system. A maintenance log must be maintained indicating dates, type of service performed and the certified Kwik-Wall distributor who performed the service.

KWIK-WALL SHALL NOT BE LIABLE FOR ANY CONSEQUENTIAL OR INCIDENTAL DAMAGES. ALL OTHER WARRANTIES EXPRESSED OR IMPLIED INCLUDING ANY IMPLIED WARRANTY OF MERCHANTABILITY ARE HEREBY EXPRESSLY EXCLUDED.

Some states do not allow the exclusion or limitation of consequential or incidental damages, so the above limitation or exclusion may not apply to you. This warranty gives you specific legal rights, and you may have other rights, which vary from state to state.

Note:

Due to ongoing research and development, some variation may occur in product specifications and design. Please refer to your actual KWIK-WALL shop drawing(s) for exact product dimensions and specifications.

Distributed By:

