

MK-X TECHNICAL DATA

Accordion Partition

A. True pantograph frames are constructed from $\frac{3}{16}$ " [5] diameter steel rod welded to 14-gauge [2], reinforced steel hinge plates for a smooth, even opening and closing action.

B. Wheel carriers are heat-treated steel trolleys with nylon covered, ball-bearing wheels for quiet, vibration free operation.

C. Chrome finished steel handles provide a sure grip and positive closing action for ease of door movement.

D. A strong $\frac{1}{8}$ " [6] thick **steel finger latch** grabs the receiver and locks the door into the closed position.

E. Anchor posts of 14-gauge [2], roll formed steel ensure longitudinal rigidity and proper door alignment.

F. Seam-free covers have a smooth and seamless appearance. The unique internal mounting design allows the covers to be attached without unsightly horizontal seams or external buttons. Curtition offers a wide range of colors and textures in standard 21-ounce vinyl or optional acoustical carpet.

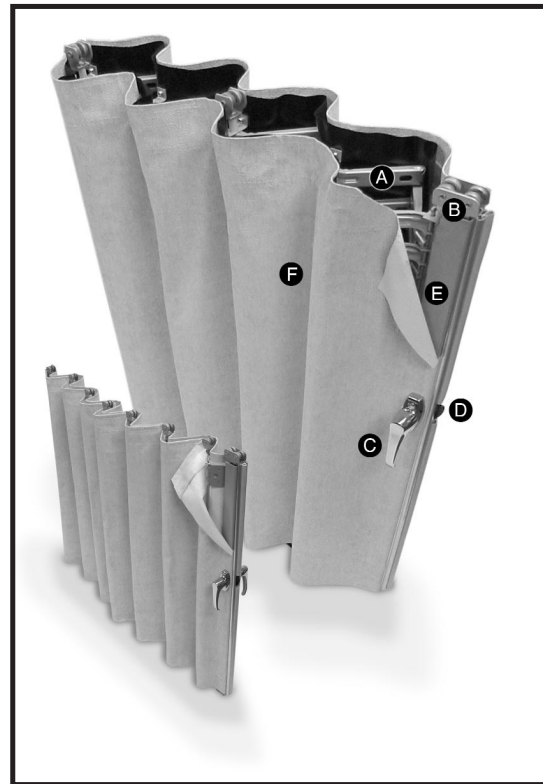

MODEL MK PRODUCT GUIDE

Sight Dividers

Model	STC Rating	Finishes	Maximum Width* ¹	Maximum Height*	Stack Depth* ²	Lead Post	Stack Width	Open Width	Hanging Weight* ³
MK-XX	-	Vinyl, Carpet	25' [7620]	16' [4877]	2.0" [50.8]	2.5" [64]	9" [229]	5" [127]	2.65 [13.2]
MK-X	-	Vinyl, Carpet	16' [4877]	12' [3658]	1.75" [44.5]	2.5" [64]	5.25" [133]	3.25" [83]	1.5 [1.74]

*¹ Paired panels double maximum width

*² Per ft. of doors width plus lead posts

*³ lbs. per sq. ft. (kg. per sq. M)



PART 1 GENERAL

1.1 SCOPE

- 1.1.1 Furnish and install accordion partition and suspension system specified.
- 1.1.2 Provide all tools, equipment and labor necessary to complete the accordion partition installation.

1.2 RELATED WORK BY OTHERS

- 1.2.1 Preparation of opening and surrounding construction.
- 1.2.2 All header, support structure, partition pockets, backing at jambs and wall surface preparation.
- 1.2.3 All adjacent structure sound attenuation work, insulation and fireproofing as required in section 1.4.

1.3 SUBMITTALS

- 1.3.1 Complete shop drawings, indicating location and product construction details. Include plans, elevations, sections, attachment to other construction, and structural support punching templates.
- 1.3.2 Partition covering samples showing full range of colors available.
- 1.3.3 KWIK-WALL's literature, including product brochures, technical sheets, installation instructions and operation and maintenance instructions as requested.

1.4 QUALITY ASSURANCE

- 1.4.1 Surface burning rating shall be class A in accordance with ASTM E 84.
- 1.4.2 Preparation of the opening shall conform to the criteria set forth per ASTM E 557.

1.5 DELIVERY AND STORAGE

- 1.5.1 Product shall be packaged for shipment from manufacturer in custom-fabricated protective wrapping.
- 1.5.2 All shipping containers shall be properly marked externally for content and destination.
- 1.5.3 Contractor shall assume responsibility for delivered product integrity if product is shipped and stored prior to installation. Contractor is responsible for product integrity after wall delivery.
- 1.5.4 Contractor shall insure the area to be used for uncrating and / or staging the accordion partition prior to installation is clean and free of debris.

1.6 WARRANTY

- 1.6.1 KWIK-WALL's limited warranty guarantees the product to be free from factory originated defects in materials and workmanship for a period of five (5) years from the date of installation.
- 1.6.2 Pantographic frame, wheels, trolleys and track shall be guaranteed against operating failure in the course of normal usage for a period of five (5) years from the date of installation.

PART 2 PRODUCTS

2.1 ACCEPTABLE MANUFACTURERS

- 2.1.1 Accordion partitions shall be Chameleon Model (select): MK-X or MK-XX manufactured by Curtition.
- 2.1.2 Other manufacturers wishing to bid product similar to Curtition Chameleon™ Series shall submit data to the architect at least ten (10) days prior to bid opening to support compliance with bid specification.
- 2.1.3 Alternative bidders shall guarantee their product specifications comply with the product specified.

2.2 OPERATION

- 2.2.1 Accordion partitions shall be non-acoustical, top supported and moved manually to the closed (latched) position or to the open (stacked) position by pulling or pushing the handle through the range of partition movement. The partition shall be secured in the closed position by the latch mechanism, tiebacks or pocket door, if specified, in the closed position.

2.3 MATERIALS

- 2.3.1 Partition covers shall be fastened to the frame with permanent rivets through concealed nylon webbing, double stitched to the inside surface. Rivets shall not penetrate outer lining and shall not be visible.
- 2.3.2 Internal framing shall be 3/16" [5]-diameter wire rod, welded to interlocking, collapsible/extendible full channel hinges and shall provide true pantographic motion. Hinges shall be custom formed 14-gauge [2mm] steel plate, welded to frame at top, bottom and intermediate points not to exceed 3'-6" [1067] vertical spacing on any partition over 6'-8" [2032] in height. Steel spacing chain shall be installed along the frame centerline to control hinge movement.
- 2.3.3 Lead and end posts shall be of minimum 14-gauge [2] box-channel steel. The lead post shall be mounted to the leading partition edge and will contain die cast chrome plated latch hardware and rubber acoustical seals. All jambs and posts shall be wrapped with the same material as the partition covers.

2.3.4 Stack dimensions shall be:

Stack Dimensions		
	MK-XX	MK-X
Stack Depth (in./ft. of doors)	2.0"	1.3" (add 2.5" for lead post)
Stack Width	9" [2.29]	5.25" [133]

2.3.4 Hanging weight shall be:

Hanging Weight		
	MK-XX	MK-X
lbs./sq. ft. (kg/sq. m.)	2.68 [12.9]	1.5 [7.3]

2.4 FINISHES

2.4.1 Panel face finish shall be factory-applied Class "A" rated material (select):

- (A) Reinforced vinyl fabric with woven backing weighing not less than 21 ounces per yard [653 g/m].
- (B) Carpet of non-woven, 100% Polyester staple fiber with fusible latex backing weighing not less than 23 ounces per yard [715 g/m].
- (C) Customer supplied material. (subject to factory approval)

2.5 OPTIONS

2.5.1 Available options shall include:

- (A) Locks: one or both sides
- (B) Radius construction for curved applications
- (C) Track switches for alternate storage or multilocation applications
- (D) Floating posts for latching of multiple partitions in L, T and X configurations
- (E) Sliding jamb boards for pocket storage

2.6 SUSPENSION SYSTEM

2.6.1 Track shall be Curtition #4 architectural grade aluminum extrusion with custom taper design to prevent wheel chatter. Optional aluminum ceiling guard shall be available. Track mounting shall be (select): Surface Mounted or Concealed.

2.6.2 Frame shall be supported by 1" [25] steel wheels mounted over matched precision bearings, with nylon tires affixed to load rated, heat treated swivel joint carriers.

2.6.3 Carriers shall be four-wheel units at the lead post and two-wheel units at every support point, with spacing of carriers not to exceed 11" [279] apart.

PART 3 EXECUTION

3.1 PREPARATION

- 3.1.1 Preparation of opening to house accordion partition shall be by others in accordance with architectural plans, KWIK-WALL's shop drawings and ASTM E 557.
- 3.1.2 Prior to installation, a KWIK-WALL authorized representative shall inspect the accordion partition. Any discrepancies noted shall be brought to the attention of the site supervisor, architect and manufacturer for remediation.

3.2 INSTALLATION

- 3.2.1 Installation shall be accomplished in strict accordance with approved shop drawings and architectural plans.
- 3.2.2 Installation shall be accomplished by factory authorized representatives in full compliance with manufacturer's written instructions (included with each shipment).
- 3.2.3 General Contractor shall be responsible for on-site product integrity.
- 3.2.4 Installer shall train owner's representatives in proper wall operation and maintenance.
- 3.2.5 Installer shall insure removal and proper disposal of all shipping materials and packaging associated with the accordion partitions from the work site upon completion of the installation.

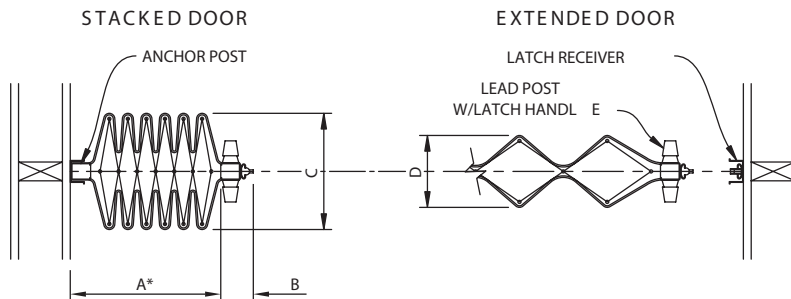

MODEL MK PRODUCT GUIDE Sight Dividers								
Model	STC Rating	Single Door Max. Opening Width	Single Door Max. Opening Height	"A"* Stack Depth per ft. of Door Width	"B" Lead Post Dimension	"C" Stack Width	"D" Extended Width	Door Weight lbs./sq. ft. (kg/sq. m.)
MK-XX	-	25' (7.63m)	16' (4.9m)	2.6" [66.04]	2.5" [64]	9" [229]	5" [127]	2.65 [12.9]
MK-X	-	16' (4.9m)	12' (3.7m)	1.3" [33.02]	2.5" [64]	5.25" [133]	3.25" [83]	1.5 [1.74]

*Stack Depth is for vinyl finish. Add 3/4" [63] per foot of door width for carpet finish.

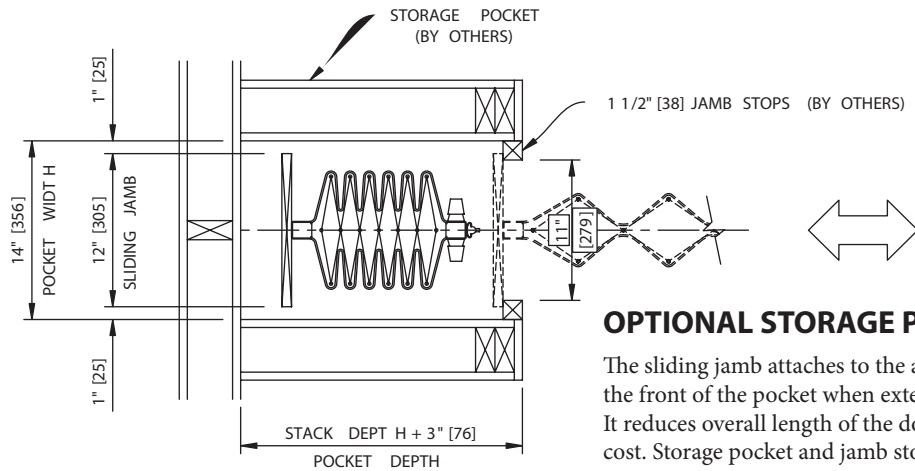
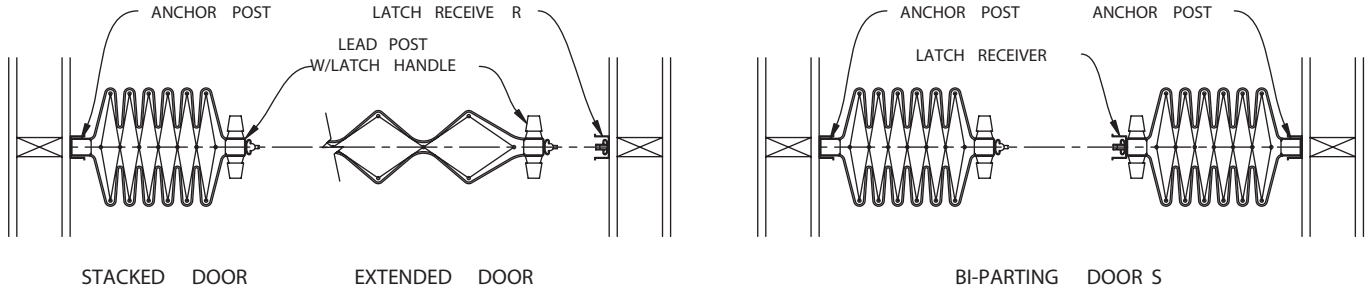

OPTIONAL STORAGE POCKET W/SLIDING JAMB

The sliding jamb attaches to the anchor end of the door and slides to the front of the pocket when extending the door. It reduces overall length of the door required, reducing stack depth and cost. Storage pocket and jamb stops by others.

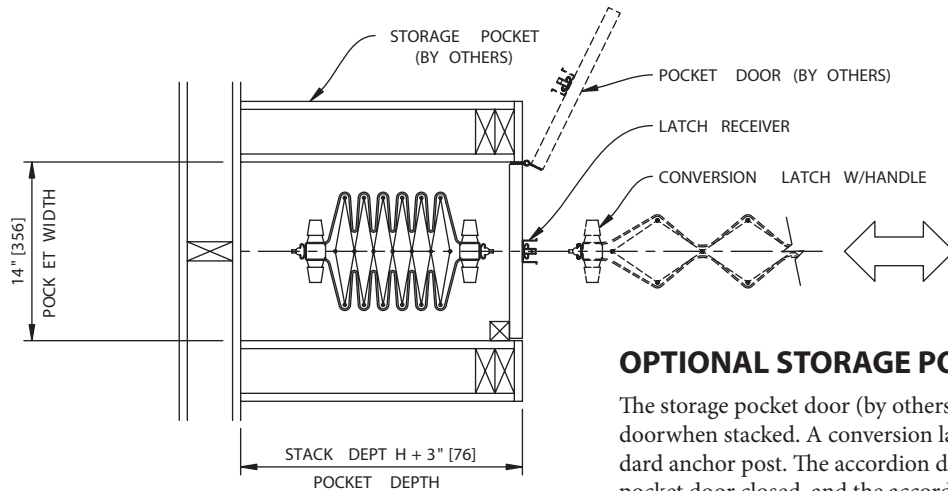

OPTIONAL STORAGE POCKET W/DOOR

The storage pocket door (by others) conceals the accordion door when stacked. A conversion latch and receiver replaces the standard anchor post. The accordion door is moved out of the pocket, the pocket door closed, and the accordion door is latched to the receiver mounted to the pocket door.

HORIZONTAL SECTIONS

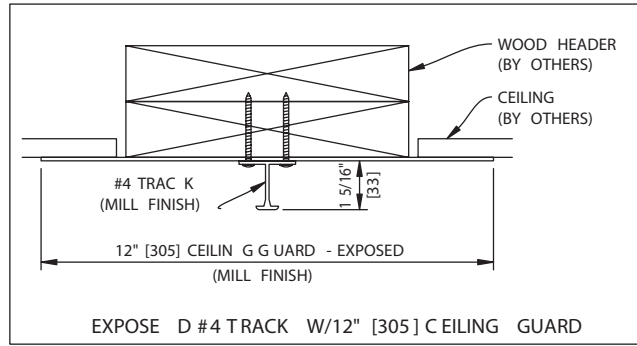
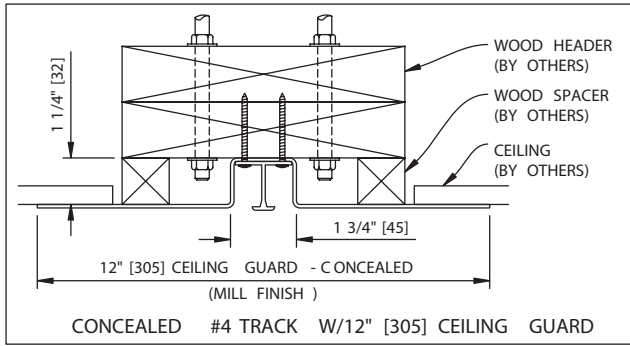
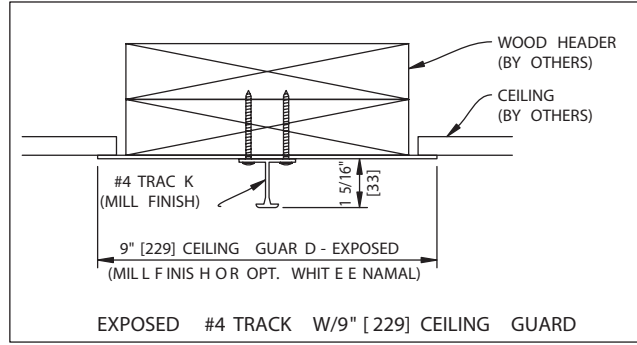
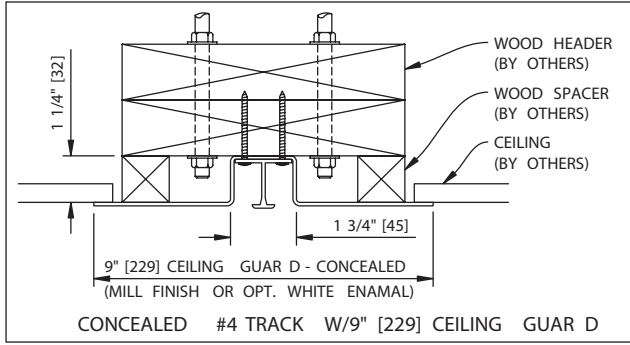

HEAD DETAILS

DOOR SHOWN WITH CONCEALED #4 TRACK AND 9" [229] CEILING GUARD.

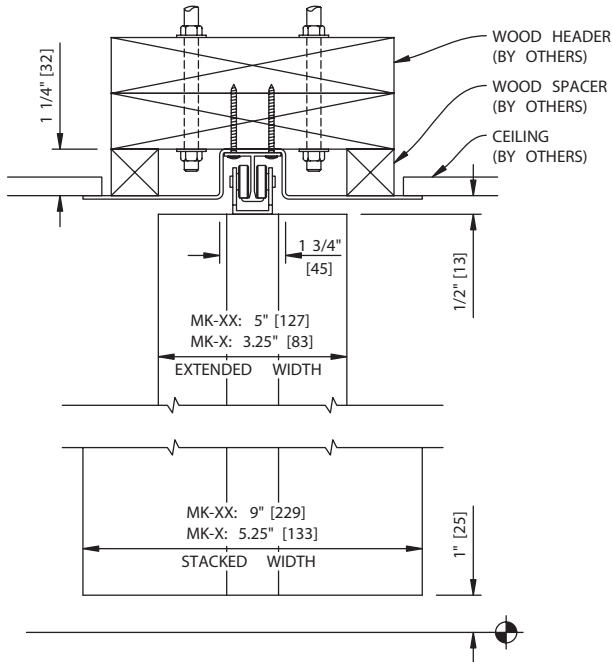

DOOR SHOWN WITH EXPOSED #4 TRACK AND 9" [229] CEILING GUARD.

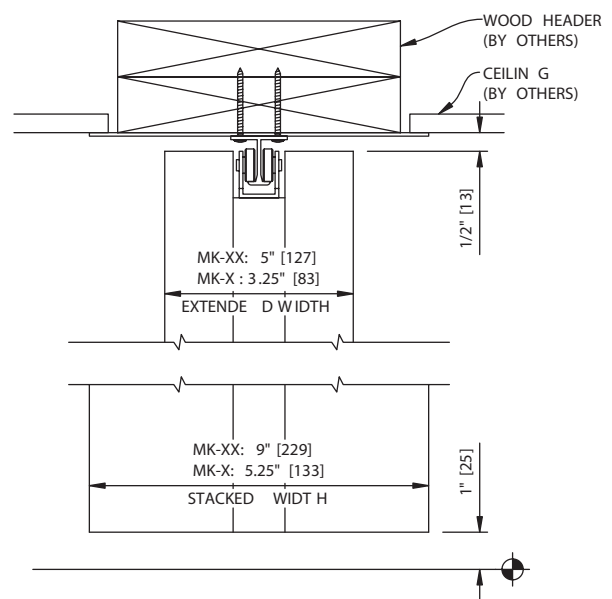

VERTICAL SECTIONS

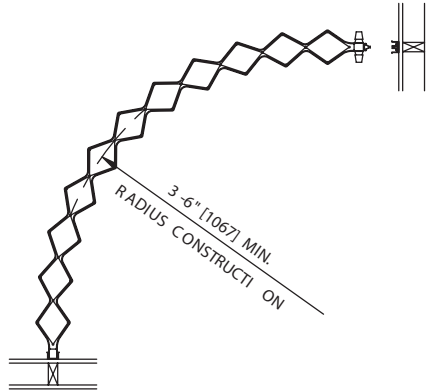

CURVED TRACK/RADIUS CONSTRUCTION

#4 track can be custom made to fit almost any curve of at least 3'-6" [1067] radius. Accordion doors with optional radius construction can follow curves and straight track.

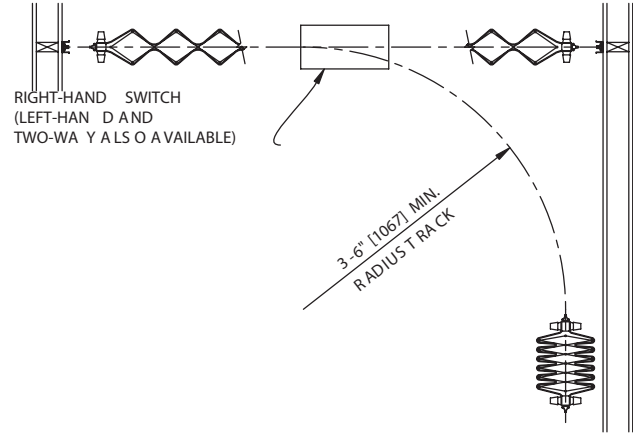

TRACK SWITCH

Accordion doors with radius construction can be stacked in remote locations by using single or two-way track switches.

COMBINE CURVES, SWITCHES, RADIUS DOOR CONSTRUCTION AND MOVEABLE POSTS TO CREATE ALMOST ANY LAYOUT.

PLAN VIEW

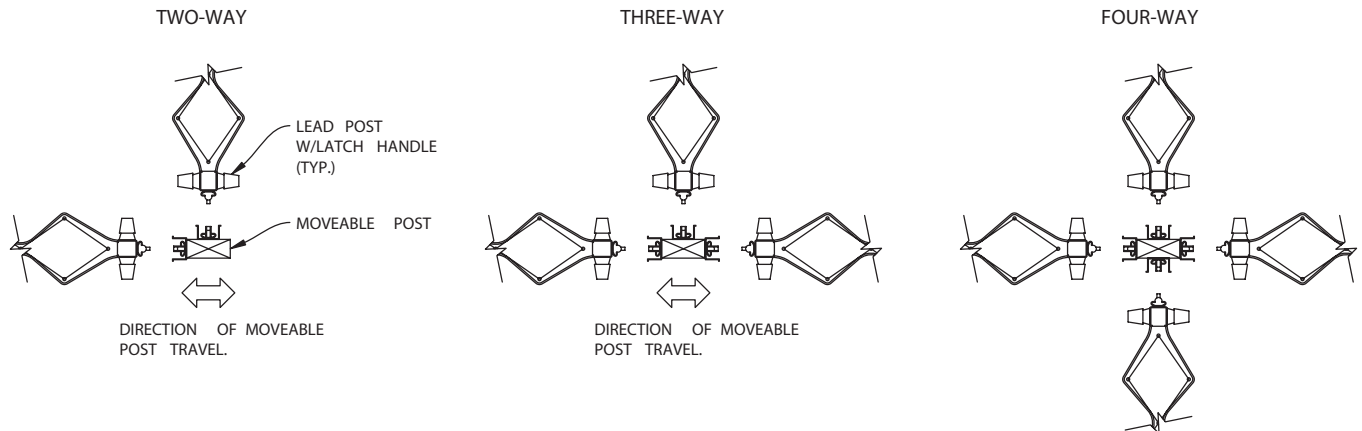

MOVEABLE MEETING POSTS

Moveable meeting posts allow two, three or four doors to latch together without the need for a permanent post structure.

HORIZONTAL SECTIONS



Kwik-Wall Company warrants each accordion door and its component parts to be free from defects in material and workmanship for a period of five (5) years from date of delivery to the original purchaser, when installed by an authorized Kwik-Wall distributor. Kwik-Wall reserves the right to have authorized personnel inspect any part alleged to be defective and to refuse any returned material unless the return was previously authorized by Kwik-Wall. (Glass is specifically excluded from the warranty.)

Upon examination by an AUTHORIZED KWIK-WALL REPRESENTATIVE, Kwik-Wall agrees to correct either by repairing or replacing any part or parts that is or has become defective through normal use and service. Kwik-Wall does not agree to warranty any parts or materials that have become defective through abuse, accident, neglect or damage in transit. Kwik-Wall does not assume any responsibility for unauthorized repairs to partitions even if it is defective. All service work performed by a distributor or party other than Kwik-Wall must be pre-approved as to work performed, time required and any cost involved.

This warranty is in lieu of all other warranties, expressed or implied. No representative or person is authorized to assume for us any of the liability in connection with the sale of our products. Kwik-Wall shall not be liable for consequential damages and in no case shall the liability exceed the original cost of the partition.

This warranty does not apply to any damage or deterioration caused by abuse or failure to provide reasonable and necessary maintenance. All field applied finishes, accessories or product modifications are specifically excluded under this warranty. Kwik-Wall's liability hereunder is limited to the replacement of any partition or component part found to be defective. Labor charges are the responsibility of the customer.

KWIK-WALL SHALL NOT BE LIABLE FOR ANY INCIDENTAL OR CONSEQUENTIAL DAMAGES. ALL OTHER WARRANTIES EXPRESSED OR IMPLIED INCLUDING ANY IMPLIED WARRANTY OF MERCHANTABILITY ARE HEREBY EXPRESSLY EXCLUDED.

Some states do not allow the exclusion or limitation of consequential or incidental damages, so the above limitation or exclusion may not apply to you.

This warranty gives you specific legal rights, and you may also have other rights which vary from state to state.

Note:

Due to ongoing research and development, some variation may occur in product specifications and design. Please refer to your actual KWIK-WALL shop drawing(s) for exact product dimensions and specifications.

Distributed By:

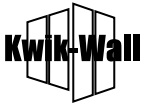

Accordion Partitions
10 22 26 (10650)

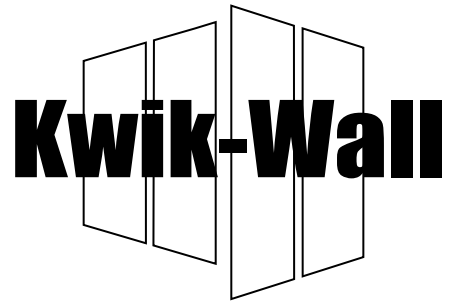

4650 Industrial Ave. • Springfield, IL 62703, USA
P: 217-522-5553 • F: 217-522-1170 • E: kwinfo@kwik-wall.com • www.kwik-wall.com



A Division of Kwik-Wall.