



# Luminous™ – Movable Glass Walls by Kwik-Wall

## Technical Data

STELLA · NOVA · **ATLAS** · LUNA · ILLONA · AVA

### ATLAS™ – Hinged, Paired Panels, 48, 43 STC

#### SECTION 10 22 39 FOLDING PANEL PARTITIONS

#### SECTION 10 22 39.13 FOLDING GLASS-PANEL PARTITIONS

## Overview

### Panel Type

- Individual
- Hinged-Paired
- Continuously-Hinged

### Partition Support

- Top Support
- Floor Support

### Stacking Configurations

- Centerline
- Offset
- Remote
- Bi-Parting

### Operation – Panels

- Manual
- Electric

### Operation – Top Seals

- Fixed, continuous contact

### Operation – Bottom Seals

- Standard: Adjustable fixed
- Optional: Operable]
- Optional: Automatic ]

### Panel Finish *(non-glass panel finish)*

- All Kwik-Wall operable wall finishes

### Panel Thickness 4" 3"

### Sound Control

- 48 STC – [4" panel thickness only]
- 43 STC – [4" panel thickness only]
- 38 STC – [3" panel thickness only]

### Power Requirement

- Yes – Continuously-hinged electric operation
- No – Manual operation configurations

**Luminous Atlas** Folding Glass Panel Partitions combine rugged, durable operable wall DNA with insulated glass units, delivering up to 80% of the panel surface area as clear viewing glass for maximum daylighting without sacrificing premium sound control!

Available with 48 STC or 43 STC certified sound control, Atlas **Hinged, Paired Panels** are simple and easy to set up, operating on a single centerline track with panel stacking at one or both perimeter walls

Atlas from Kwik-Wall is the new standout glass operable wall hybrid option.



**WEIGHTS:**  
10.6-10.8 lbs. / sq. ft.  
[52 - 53 kg/m<sup>2</sup>]



More Information



### ATLAS™ – Hinged, Paired Panels, 48, 43 STC

#### SECTION 10 22 39 FOLDING PANEL PARTITIONS

#### SECTION 10 22 39.13 FOLDING GLASS-PANEL PARTITIONS

#### PART 1 – GENERAL SPECIFICATIONS

##### 1.01 WORK INCLUDED

- A. The folding glass-panel partition system shall be furnished, installed, and serviced by the wall manufacturer's authorized distributor, in compliance with the architectural drawings and specifications contained herein.

##### 1.02 RELATED WORK

- A. Structural Support: The structural support system required for suspending the folding glass-panel partition system shall be designed, installed, and pre-punched by others, in accordance with ASTM E 557, and the manufacturer's shop drawings.
- B. Insulation: Sound insulation and baffles for the plenum area above the track system, under the permanent floor, inside air ducts passing over or around the folding glass panel partition, and in permanent walls adjoining the folding glass panel partition system shall be by others, in accordance with ASTM E 557.
- C. Opening Preparation: Proper and complete preparation of the folding glass-panel partition system opening shall be by others in accordance with ASTM E 557 and shall include floor leveling; plumbness of adjoining permanent walls; substrate and/or ceiling tile enclosures for the track system; and the painting and finishing of trim and other materials adjoining the head and jamb areas of the folding glass panel partition. Any permanent wall(s) receiving an adjustable or fixed wall jamb will require internal structural blocking to secure the jamb to the permanent wall. Refer to a copy of the shop drawings for additional details.

##### 1.03 SYSTEM DESCRIPTION

- A. The folding glass-panel partition system shall consist of hinged pairs operation, featuring panels hinged together in evenly matched pairs (groups of two (2)), unless otherwise specified.
- B. The folding glass-panel partition system shall consist of acoustically rated panels tested in accordance with ASTM E 90 and ASTM E 413 test procedures, and shall have achieved a STC rating as specified herein (see "Acoustical Performance" article listed under Part 2 – Products).

##### 1.04 QUALITY ASSURANCE

- A. The folding glass-panel partition system shall have been tested in an independent acoustical testing laboratory in accordance with ASTM E 90 and ASTM E 413 test procedures.
- B. The folding glass-panel partition construction and finish materials shall consist of Class A-rated materials in accordance with ASTM E 84.
- C. The folding glass-panel partition shall be installed by the manufacturer's authorized distributor in accordance with ASTM E 557.

##### 1.05 REFERENCES

- A. ASTM E 90: Laboratory Measurement of Airborne-Sound Transmission Loss of Building Partitions.
- B. ASTM E 413: Determination of Sound Transmission Class (STC).
- C. ASTM E 557: Architectural Application and Installation of Operable folding glass panel partitions.
- D. ASTM E 84: Surface Burning Characteristics of Building Materials.
- E. ASTM A 653: Specification for General Requirements for Steel Sheet, Alloy-Coated (Galvannealed) by the Hot Dip Process.
- F. ASTM C 423: Standard Test Method for Sound Absorption and Sound Absorption Coefficients by the Reverberation Room Method.
- G. CCC-W-408A: Federal Specification which applies to Vinyl Coated Wall Coverings.
- H. CFFA-W-101-D: Chemical Fabrics and Film Association Quality Standard for Vinyl Coated Fabric Wall Coverings.
- I. ASTM E 2190: Certification and testing for Insulated Glass inserts.

##### 1.06 SUBMITTALS

- A. Manufacturer shall provide written technical information and related detail drawings, which demonstrate that the products comply with contract documents for each type of folding glass panel partition specified.
- B. Manufacturer shall provide detailed engineering drawings featuring track plan, panel elevation, horizontal and vertical details, and beam punching template as required.
- C. Manufacturer shall provide a written test report of the independent acoustical testing laboratory certifying the attainment of the specified STC rating, upon request.
- D. Manufacturer shall provide written instructions specifying the proper operation and maintenance of the folding glass-panel partition system.
- E. Manufacturer shall provide a color selector demonstrating the manufacturer's selections of the specified finish material. Samples shall consist of actual swatches of the specified finish material.

##### 1.07 DELIVERY, STORAGE, AND HANDLING

- A. The folding glass panels shall be individually wrapped in a protective plastic covering to keep the panels clean during delivery, storage, and handling.
- B. The folding glass panels shall be stored on edge and above the floor on cushioned blocking in a dry and ventilated area, protected from humidity and temperature extremes.



### ATLAS™ – Hinged, Paired Panels, 48, 43 STC

#### SECTION 10 22 39 FOLDING PANEL PARTITIONS SECTION 10 22 39.13 FOLDING GLASS-PANEL PARTITIONS

##### 1.08 SEQUENCING / SCHEDULING

- A. Beam Punching: Manufacturer shall provide a beam punching template drawing detailing the anchor locations for the suspended track system (as required for Drop Rod Mounting), as required for the fabrication and installation of structural overhead support by others.
- B. Track Installation: Scheduling of folding glass panel partition installation shall occur after structural overhead support has been properly and completely fabricated and installed by others.
- C. Glass Panel Installation: The folding glass panel installation shall occur after fixed wall substrate construction is properly and completely installed by others, as required to protect panels from ongoing adjacent construction.

##### 1.09 WARRANTY

The manufacturer shall warrant each folding glass panel partition panel and its component parts to be free from defects in material and workmanship for a period of five (5) years from the date of delivery to the original purchaser, when installed by an authorized KWIK-WALL distributor. KWIK-WALL also warrants the fixed top seals, track, carriers, and its component parts to be free from defects in material and workmanship for a period of ten (10) years. (Contact your local KWIK-WALL Distributor or KWIK-WALL Company for complete warranty information.) (Glass is specifically excluded from the warranty.)

## PART 2 – PRODUCT SPECIFICATIONS

### 2.01 ACCEPTABLE MANUFACTURER

- A. The folding glass panel system shall be Luminous, Atlas - hinged pairs as manufactured by KWIK-WALL Company.

### 2.02 PANEL CONSTRUCTION

- A. Panel Dimensions: Standard panel dimension shall be nominal 4" [101.6] thick, and nominal 48" [1219] wide.
- B. Panel Frame: Steel frame shall be 16-gauge galvanized steel; the horizontal top cross member shall be a minimum 12-gauge galvanized steel that meets or exceeds ASTM A 653 requirements. Frame shall be all-welded construction with steel corner supports and cross-bracing reinforcement. Panel frame shall be Class A-rated, fire-retardant, non-combustible, and non-corrosive in accordance with ASTM E 84.
- C. Panel Skins: Panel skins shall be Class A rated (except Wood Veneer and High-Pressure Laminate) in accordance with ASTM E 84. Panel skin material shall consist of (select):
  1. Standard Steel Skins: consisting of minimum 22-gauge tension-leveled galvanized steel, pressure laminated to a structural acoustical backer and mechanically joined to the steel frame to form a rigid, unitized, and structural panel.

2. Optional Acoustical Substrate: consisting of a structural acoustical substrate pressure-laminated to both sides of the steel frame to form a rigid, unitized, and structural panel.
3. Optional Wood Veneer: consisting of particle board core, covered with wood veneer and pressure laminated to both sides of the steel frame to form a rigid, , and structural panel.
4. Optional High-Pressure Laminate: consisting of gypsum board core covered with general-purpose plastic laminate and Phenolic backer sheet, which is pressure-laminated to both sides of the steel frame to form a rigid, unitized, and structural panel.

- D. Glass: Opening cut out in panel shall be glazed with an insulated glass unit that is manufactured in accordance with ASTM E 2190. Glass type shall be an acoustical-insulated glass unit. Glass shall be retained in the opening cut out using an aluminum extrusion.
  1. 43 STC - 1 3/4" overall thickness, 1/2" laminated glass - 1" air space - 1/4" tempered glass
  2. 48 STC - 1 7/8" overall thickness, 1/2" laminated glass - 1" air space - 3/8" tempered glass.
- E. Panel Hinges: Panel hinges shall be (select)
  1. Architectural grade, full-leaf butt hinges.
  2. Concealed hinges, (optional).
- F. Panel Weight: Maximum panel weight shall be 10.6 – 10.8 lb./ft.2 (52 – 53 kg/m2) depending on STC rating, size and options selected.

### 2.03 OPERATION

- A. Operation shall be Hinged Pairs, consisting of panels hinged together in groups of two (2), unless otherwise specified. Panels shall be top supported by one (1) carrier in each panel.

### 2.04 STACK ARRANGEMENTS

- A. Stack Type: Panel storage configuration shall be Center Stacking, consisting of panels stacked on center to the wall's installed position.
- B. Stack Quantity: Panels shall be stored at (select):
  1. Standard One End: on one perimeter end of the opening centerline.
  2. Optional Both Ends: on both perimeter ends of the opening centerline.



### ATLAS™ – Hinged, Paired Panels, 48, 43 STC

#### SECTION 10 22 39 FOLDING PANEL PARTITIONS SECTION 10 22 39.13 FOLDING GLASS-PANEL PARTITIONS

##### 2.05 FINISHES

- A. Finish Material Type: Panel finish material shall be Class A (except wood veneer and high-pressure laminate) rated in accordance with ASTM E 84, consisting of (select):
  - 1. Vinyl: consisting of Type II, reinforced vinyl weighing 21 oz./lin. yd. (651 g/lin. m). Vinyl shall meet or exceed CCC-W-408A and CFFA-W-101-D quality standards.
  - 2. Optional Upgrade Fabric: consisting of fade and tear-resistant fabric that resists water-based stains, weighing 13 oz./lin. yd. (403 g/lin. m).
  - 3. Optional Standard Carpet: consisting of acoustically absorbent, non-woven needle punch fibers fused to prevent fraying and unraveling of material weighing 28.5 oz./lin. yd. (884 g/lin. m). Basics Carpet shall achieve a minimum NRC (Noise Reduction Coefficient) rating of .20 (applied over gypsum substrate) in accordance with ASTM C 423.
  - 4. Optional Upgrade Carpet: consisting of acoustically-absorbent, non-woven needle punch fibers fused to prevent fraying and unraveling of material weighing 23 oz./lin. yd. (713 g/lin. m). Upgrade Carpet shall achieve a minimum NRC (Noise Reduction Coefficient) rating of .25 (applied over gypsum substrate) in accordance with ASTM C 423.
  - 5. Optional Wood Veneer: consisting of unfinished flat cut wood veneer laminated to 1/2" [12.7] thick particle board core. Veneer shall be book / running matched within a panel, and edge-banded if trimless astragals are specified.
  - 6. Optional High-Pressure Laminate: consisting of gypsum board core covered with general-purpose plastic laminate and Phenolic backer sheet, which is pressure-laminated to both sides of the steel frame to form a rigid, unitized, and structural panel.
  - 7. Optional Unfinished: consisting of panels with exposed acoustical substrate or steel skins for field-applied wall covering or painting.
- B. Finish Material Supplier: Finish material shall be (select):
  - 1. Standard Factory Supplied: from the manufacturer's standard selection of finish materials, as specified.
  - 2. Optional Customer Supplied: from the customer's selection of finish material, by others, and as approved by KWIK-WALL Company.
- C. Finish Material Application: Finish material shall be (select):
  - 1. Standard Factory Applied: by folding glass panel partition manufacturer. Customer-supplied finish material samples must be submitted to the manufacturer for testing and approval prior to acceptance and application.
  - 2. Optional Field Applied: by others.

##### 2.06 PERIMETER TRIM AND SEALS

- A. Vertical Trim and Seals: The folding glass panels shall have vertical astragals containing flexible vinyl seals and incorporate reversible tongue-and-groove-type configurations for positive interlocking with adjacent panels. Vertical astragal type shall be (select):
  - 1. Standard Trimless Astragal: consisting of an aluminum extrusion with tongue-and-groove-type vertical astragals. Vertical trim shall not be permitted on the panel faces, resulting in a minimal groove appearance between adjacent panels.
  - 2. Optional Cap-type Astragal: consisting of an aluminum extrusion with tongue-and groove-type vertical astragals for encapsulating and protecting the finish material and substrate along the vertical edge of the panel.
- B. Horizontal Top Trim and Seals: Top seals shall consist of flexible vinyl sweep seals installed on both sides of the panel. The seals shall consist of a compressed bulb between two (2) fingers of vinyl. Top seal type shall be (select):
  - 1. Standard Fixed Top Seals: consisting of continuous-contact flexible vinyl sealing against the bottom flange of the overhead track.
- C. Horizontal Bottom Trim and Seals: Bottom seals shall consist of multiple fingers of flexible vinyl for positive contact and sealing with various floor surfaces. Bottom seal type shall be (select):
  - 1. Standard Operable Bottom Seals: consisting of an edge-activated seal using a removable wrench as supplied by the manufacturer. Bottom seals shall provide 2" [50.8] of nominal travel.
  - 2. Optional Adjustable Bottom Seals: consisting of field-adjustable, continuous-contact vinyl sweep seals with 2" [50.8] nominal height with 3/4" [19] of nominal adjustment.
  - 3. Optional Automatic Bottom Seals: consisting of self-activated seals providing 2" [50.8] of nominal travel.
- D. Horizontal and Vertical Panel Trim: All exposed panel trim and hinges shall be of one (1) similar color (select):
  - 1. Dark Bronze.
  - 2. Grey.

##### 2.07 CLOSURE SYSTEMS

- A. Initial Closure System: The lead panel (the first panel exiting the stack) shall form a seal vertically against a rigid wall surface, as accomplished by a (select):
  - 1. Standard Bulb Seal: consisting of continuous-contact, flexible vinyl bulb seal(s) installed along the vertical edge of the lead panel for positive compression against a rigid wall surface.
  - 2. Optional Fixed Starter Jamb: consisting of an aluminum



### ATLAS™ – Hinged, Paired Panels, 48, 43 STC

#### SECTION 10 22 39 FOLDING PANEL PARTITIONS SECTION 10 22 39.13 FOLDING GLASS-PANEL PARTITIONS

extrusion, which is permanently mounted to a structural wall surface. The Fixed Starter Jamb shall incorporate a tongue-and-groove-type vertical astragal for positive interlocking with the lead panel.

3. Optional Adjustable Starter Jamb: consisting of an aluminum extrusion which is permanently mounted to a structural wall surface and is field-adjustable to compensate for out-of-plumb conditions of the fixed wall. The Adjustable Starter Jamb shall incorporate a tongue-and-groove-type vertical astragal for positive interlocking with the lead panel.
- B. Final Closure System: The final closure panel (the last panel exiting the stack) shall form a seal vertically against a rigid wall surface. The type of final closure panel shall be (select):
  1. Standard Expander Panel Closure: consisting of an expander mechanism with a nominal 5" [127] of travel, activated from the face of the panel using a removable wrench as supplied by the manufacturer. The Expander Panel shall be equipped with an adjustable bottom seal (standard) or (optional) operable bottom seal, and a flush pull handle.
  2. Optional Hinged Panel(s) Closure: consisting of a half-panel hinged permanently and directly to a structural wall surface. The Hinged Panel(s) shall be equipped with an adjustable bottom seal, a lap-type extrusion for sealing against its adjacent panel (standard) or (optional) expander mechanism with a nominal 5" [127] of travel, activated from the face of the panel using a removable wrench, and a flush pull handle on each side of the panel.
  3. Optional Communicating Panel Closure: consisting of a full-sized panel hinged permanently and directly to a structural wall surface. The Communicating Panel shall function as a full height pass door (maximum panel size: 3'-0" (.91 m) wide x 10'-2" (3.10 m) high), with an adjustable bottom seal, a lap-type extrusion for sealing against its adjacent panel, and a flush pull handle on each side of the panel.
  4. Optional Lap Closure: consisting of a pair of panels equipped with bulb seals for sealing against a rigid wall surface on one side, and a lap-type extrusion that overlaps with the adjacent panel on the opposite side. The Lap Closure panel shall be equipped with adjustable bottom seals, and a flush pull handle.
  5. Optional Single Panel Expander Closure: consisting of an expander mechanism with a nominal 5" [127] of travel, activated from the face of the panel using a removable wrench. The Single Panel Expander shall be capable of rotating 360° and shall be equipped with an adjustable bottom seal (standard) or (optional) operable bottom

seal, and a flush pull handle.

6. Optional Pocket Door(s): (see 3000 Series Pocket Door technical data sheet for complete details and specifications).

Note: Optional Automatic Bottom Seal is not available in conjunction with Final Closure panel(s).

#### 2.08 ACOUSTICAL PERFORMANCE

- A. Certification. The folding glass panels shall have been tested in an independent acoustical testing laboratory in accordance with ASTM E 90 and ASTM E 413 test procedures.
- B. STC Rating: The folding glass panel system's acoustical performance rating shall be based on (select):

#### 2.09 PANEL ACCESSORIES

- A. Accessories, including Pass Doors; Single or Double, Keyed Cylinder Locks, Concealed Door Closures, Exit Signs, Pocket Doors, shall be compatible with other accessories and options, furnished and installed by the folding glass panel system's manufacturer, as noted on submitted shop drawings.
  5. Optional Single Panel Expander Closure: consisting of an expander mechanism with a nominal 5" [127] of travel, activated from the face of the panel using a removable wrench. The Single Panel Expander shall be capable of rotating 360° and shall be equipped with an adjustable bottom seal (standard) or (optional) operable bottom seal, and a flush pull handle.
  6. Optional Pocket Door(s): (see 3000 Series Pocket Door technical data for complete details and specifications). Note: Optional Automatic Bottom Seal is not available in conjunction with Final Closure panel(s).

#### 2.10 TRACK SYSTEMS

- A. Track Type: The folding glass panel system shall be (select):
  1. Standard Hinged Pairs Aluminum Track: extruded from structural aluminum alloy, which prohibits deterioration caused by rust or corrosion. The aluminum track shall have a durable anodized clear satin finish, which resists color fading and flaking. The track shall utilize grooves and interlocking steel pins for positive alignment of adjacent track sections. The track joints shall be reinforced overhead by a heavy-duty steel bracket made of hot-rolled, 3/8" [10] thick plate steel. Aluminum track shall include an integral, continuous nut slot raceway to accept hardened steel square nuts to facilitate attachment of each steel all-rod and splice brackets to the overhead structural support.
  2. Optional Hinged Pairs Steel Track: For panels up to 900lbs [408kg]. Track shall be of 3/16" [5] formed black



### ATLAS™ – Hinged, Paired Panels, 48, 43 STC

#### SECTION 10 22 39 FOLDING PANEL PARTITIONS SECTION 10 22 39.13 FOLDING GLASS-PANEL PARTITIONS

painted steel connected to the structural support by pairs of 3/8" threaded steel hanger rods. Track trim shall be clear anodized aluminum. Carriers to have four steel wheels with precision-ground radial bearings. Minimum dimension from the ceiling to the structure is 8" [203].

- B. Track Size: The track size shall be (selected from Track and Carrier Selection Chart – refer to Page 1):
1. Type 425 Hinged Pairs Aluminum Track: certified to be capable of supporting up to 525 lb. (238 kg) of total live load weight per panel.
  2. Type 425 Hinged-pairs Aluminum Track with integral steel tread surface
  3. Type 850 Hinged Pairs Aluminum Track: certified to be capable of supporting up to 850 lb. (386 kg) of total live load weight per panel.
  4. Type 850 Hinged-pairs Aluminum Track with integral steel tread surface.
  5. Type 11L Hinged Pairs Steel Track: certified to be capable of supporting up to 900 lb. (408 kg) of total live load weight per panel.

#### 2.11 CARRIER SYSTEMS

- A. Carrier Type: Each Hinged Pair panel shall be top supported by one (1) carrier utilizing a 5/8" [16] diameter pendant bolt. The carrier type shall be (select):
1. Type 425 Standard Polymer Tire Carrier: consisting of four (4) permanently lubricated, precision ball bearing steel wheels with high-strength polymer tires, as required for smooth and quiet operation.
  2. Type 425 Standard Steel Tire Carrier: consisting of four (4) permanently lubricated, precision-ground ball-bearing polished steel wheels, as required for ease of panel movement.
  3. Type 850 Standard Polymer Tire Carrier: consisting of four (4) permanently lubricated, precision-ground ball bearing steel wheels as required for smooth and quiet operation.
  4. Type 850 Standard Steel Tire Carrier: consisting of four (4) permanently lubricated, precision-ground ball-bearing polished steel wheels, as required for ease of panel movement.
  5. Type 11L Steel Wheel Carrier: consisting of four (4) permanently lubricated, precision-ground ball-bearing polished steel wheels, as required for ease of panel movement.
- B. Carrier Size: The carrier size shall be (select from Track and Carrier Selection Chart – refer to Page 1):
1. Type 425 Hinged Pairs Polymer Tire Carrier: certified to

be capable of supporting up to 525 lb. (238 kg) of total live load per panel.

2. Type 850 850 steel carrier Hinged Pairs Polymer Tire Carrier: certified to be capable of supporting up to 850 lb. (386 kg) of total live load per panel.
3. Type 11L Hinged Pairs Steel Wheel Carrier: certified to be capable of supporting up to 900 lb. (408 kg) of total live load per panel.

#### 2.12 SUSPENSION SYSTEMS

- A. Mounting Systems: The track shall be supported by (select):
1. Standard Drop Rod Mount: consisting of adjustable rods of grade 2, 3/8" [10] diameter threaded steel all-rod provided with 3/8" [10] serrated steel flange nuts.
  2. Optional Direct Mount: consisting of 3/8" [10] x 3" [76] lag screws for attachment to an overhead structural (wood) support. (Direct mount track installations should not exceed 425 lbs. (193 kg) of panel weight.)
  3. Optional Drop Rod Bracket Mount: consisting of 3/8" [10] thick steel brackets mounted to the top of the track and supported with adjustable rods of grade 2, 3/8" [10] diameter threaded steel all-rod provided with 3/8" [10] serrated steel flange nuts.

### PART 3 – EXECUTION

#### 3.01 INSPECTION

- A. Proper and complete preparation of the folding glass panel system opening shall be by others in accordance with the architectural drawings, the manufacturer's shop drawings and ASTM E 557 – Standard Guide for the Installation of Operable Partitions. Any deviation of the actual opening from these specifications shall be called to the attention of the architect prior to the installation of the operable wall.
- B. Deficiencies in the operable wall opening shall be corrected by others prior to installation of the operable wall.

#### 3.02 INSTALLATION

- A. The folding glass panel system shall be installed by the manufacturer's authorized distributor.
- B. The operable wall shall be installed in accordance with the manufacturer's written instructions, shop drawings, and ASTM E 557 installation guidelines.

#### 3.03 ADJUSTING AND CLEANING

- A. The folding glass panels and track system shall be adjusted and cleaned in accordance with the manufacturer's written instructions.



**ATLAS™** – Hinged, Paired Panels, 48, 43 STC  
SECTION 10 22 39 FOLDING PANEL PARTITIONS  
SECTION 10 22 39.13 FOLDING GLASS-PANEL PARTITIONS

**3.04 PROTECTION**

- A. The folding glass panel partition panels shall be stored in the stacked (retracted) position prior to acceptance by the owner's representative.

**3.05 DEMONSTRATION**

- A. The folding glass panel partition manufacturer's authorized distributor shall demonstrate proper operation and explain proper and necessary maintenance requirements of the folding glass panel partition system to the owner's representative.

For additional information contact:

KWIK-WALL Company  
4650 Industrial Ave.  
Springfield, Illinois 62703

Phone: 217-522-5553 or 800-280-5945 (United States and Canada only)

Fax: 217-522-1170 or 800-290-5945 (United States and Canada only)

Website: [www.kwik-wall.com](http://www.kwik-wall.com)  
Email: [info@kwik-wall.com](mailto:info@kwik-wall.com)

Note:

Due to ongoing research and development, some variations may occur in product specifications.

04.2026



**ATLAS™ – Hinged, Paired Panels, 48, 43 STC**  
 SECTION 10 22 39 FOLDING PANEL PARTITIONS  
 SECTION 10 22 39.13 FOLDING GLASS-PANEL PARTITIONS

**ELEVATION DETAILS**

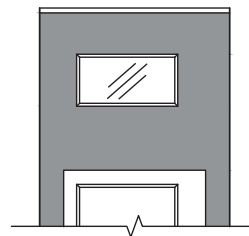
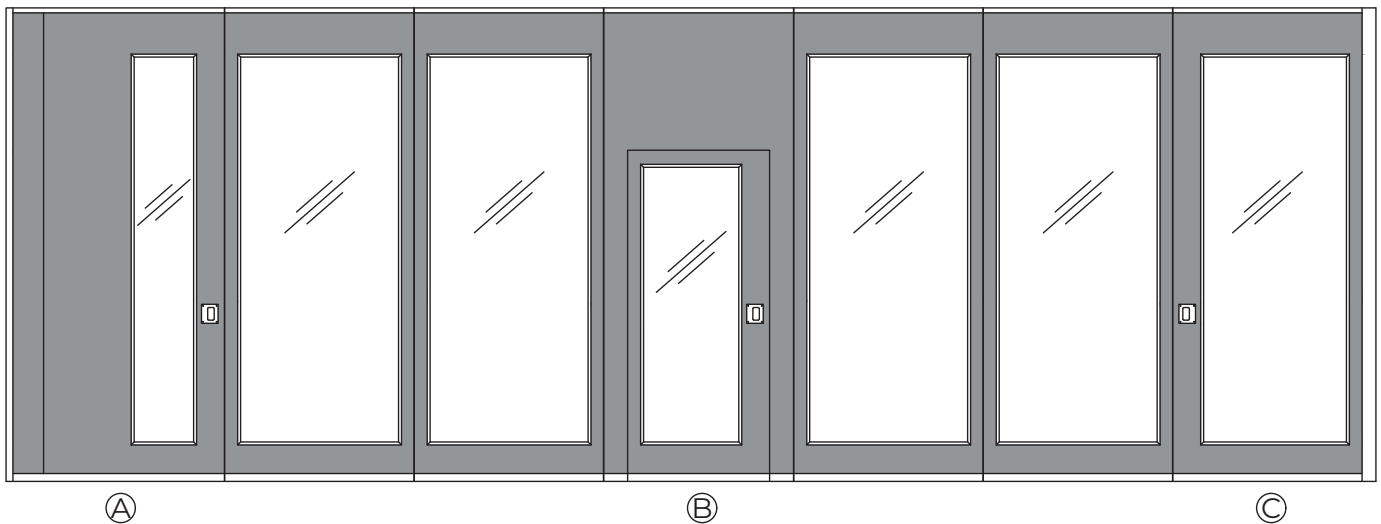

\*OPTIONAL CLEAR TRANSOM OVER INSET PASS DOOR FOR PANEL HEIGHTS OVER 10'-5 7/16" [3186]

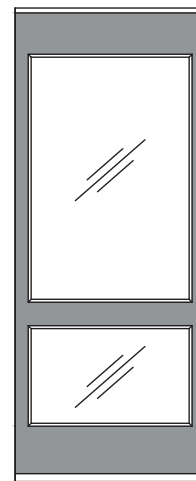

(D)

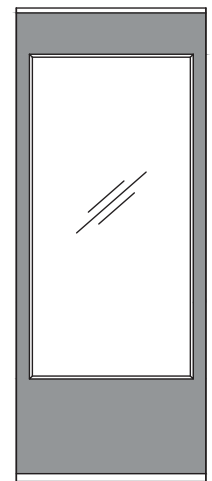

(E)

- (A) EXPANDER PANEL
- (B) INSET PASS DOOR, AVAILABLE FOR PANEL HEIGHTS OVER 7'-8" [2337] OPTIONAL PANIC HARDWARE, OPTIONAL CLEAR TRANSOM\*
- (C) COMMUNICATING PANEL, CAN BE USED AS CLOSURE METHOD IN LIEU OF EXPANDER PANEL
- (D) OPTIONAL OPERABLE BOTTOM SEALS REQUIRES LARGER BOTTOM RAIL AND HORIZONTAL MULLION
- (E) OPTIONAL AUTOMATIC BOTTOM SEALS REQUIRES LARGER BOTTOM RAIL



### ATLAS™ – Hinged, Paired Panels, 48, 43 STC

SECTION 10 22 39 FOLDING PANEL PARTITIONS  
SECTION 10 22 39.13 FOLDING GLASS-PANEL PARTITIONS

## STACKING CONFIGURATIONS

### Standard Center Stack

Panels are conveniently stored at one or both ends and stacked on-center to the wall's installed position.

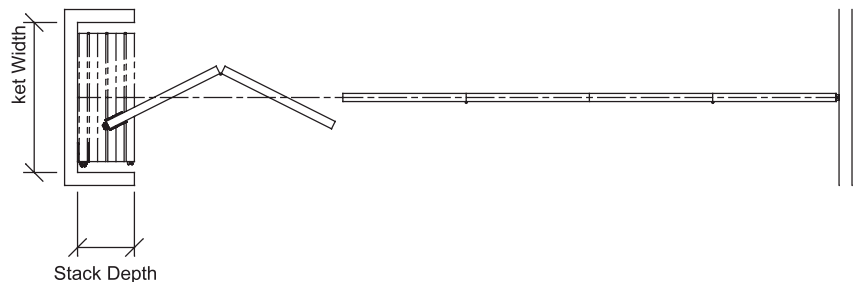

### Stack Depth\*

The overall depth of the stack area, as required for panel storage, is dictated by the total number of panels in the wall system. Luminous Atlas Panels require an average stack depth of 4 3/8" [111] per panel. To determine the stack depth, calculate as follows:

$$\text{Number of Panels} \times 4\frac{3}{8}" [111]$$

\*Note: Additional stack depth is required for wall systems containing the following type of panels:

- Expander Panel Closure or Pass Door Panel: 3/4" [19]
- Hinged Panel(s) Closure: 4" [102]
- Pocket Door(s): 6" [152]

\*\*Note: For wall systems that include Pocket Doors, please reference KWIK-WALL's "3000 Series Pocket Door" technical data sheet for pocket layout dimensions and applications.

### Pocket Width\*\*

The width of the pocket is determined by the widest panel in the wall run. For specification purposes, assume that the widest panel is 4'-0" (122 cm) maximum. Wall systems that utilize Automatic type bottom seals will require extra pocket width to allow clearance for the actuator that protrudes from the bottom of the lead panel. Pocket width may be calculated as follows:

*If Adjustable or Operable Bottom Seals are specified:*

$$\text{Widest Panel} + 7" [178]$$

(allows 3 1/2" [89] for hand clearance on each side)

*If Automatic Bottom Seals are specified:*

$$\text{Widest Panel} + 8\text{-}1/2" [216]$$

(for actuator clearance on one side)

plus

$$3\frac{1}{2}" [89]$$

(for hand clearance on the other side)



### ATLAS™ – Hinged, Paired Panels, 48, 43 STC

SECTION 10 22 39 FOLDING PANEL PARTITIONS  
SECTION 10 22 39.13 FOLDING GLASS-PANEL PARTITIONS

## STACKING CONFIGURATIONS FINAL CLOSURES

#### Optional Communicating Panel Closure

This final closure panel is a full-sized panel (maximum 3'-0" [9] wide x 10'-2" [3.10] high) which is hinged permanently and directly to a structural wall. The Communicating panel functions as a full height pass door, incorporates an adjustable bottom seal and includes a flush pull handle on each side of the panel.

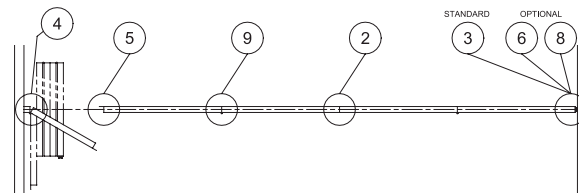

#### Optional Lap Panel Closure

The final closure is accomplished by two (2) panels equipped with bulb seals for sealing against a rigid wall surface on one (1) side, and a lap-type extrusion that overlaps with the adjacent panel on the opposite side. The lap closure panel is equipped with adjustable bottom seals and includes a flush pull handle.

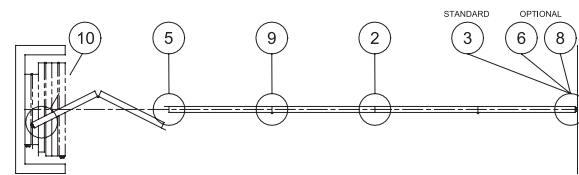

#### Optional Single Panel Expander Closure

The final closure panel is equipped with an expander mechanism in the same way as the more common expander panel. The single panel expander shall be center hung and capable of rotating 360-and, is equipped with an adjustable bottom seal (standard) or (optional) operable bottom seal and is used specifically with hinged pairs operation, and includes a flush pull handle. (Maximum panel height is 12'-2" [3.71]).

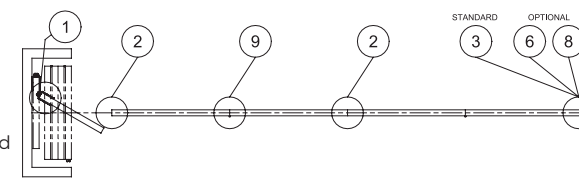

#### Optional Double Pocket Doors with Expander Closure

The pocket door is equipped with an expander mechanism in the same way as the more common expander panel. Rather than being located on a wall panel, the expander saddle is integrated into a pocket door panel. The saddle expander will be fully retracted with a pair of bulb seals compressed against the last panel exiting the stack. The pocket doors are provided with fixed bottom seals as a factory standard and includes a foot bolt and flush pull handle.

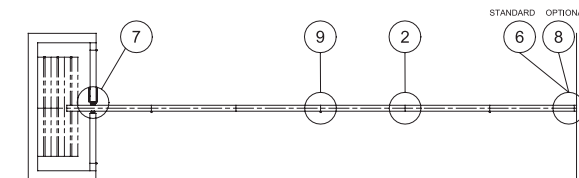



**ATLAS™ – Hinged, Paired Panels, 48, 43 STC**  
 SECTION 10 22 39 FOLDING PANEL PARTITIONS  
 SECTION 10 22 39.13 FOLDING GLASS-PANEL PARTITIONS

**HORIZONTAL TRIMLESS DETAILS**

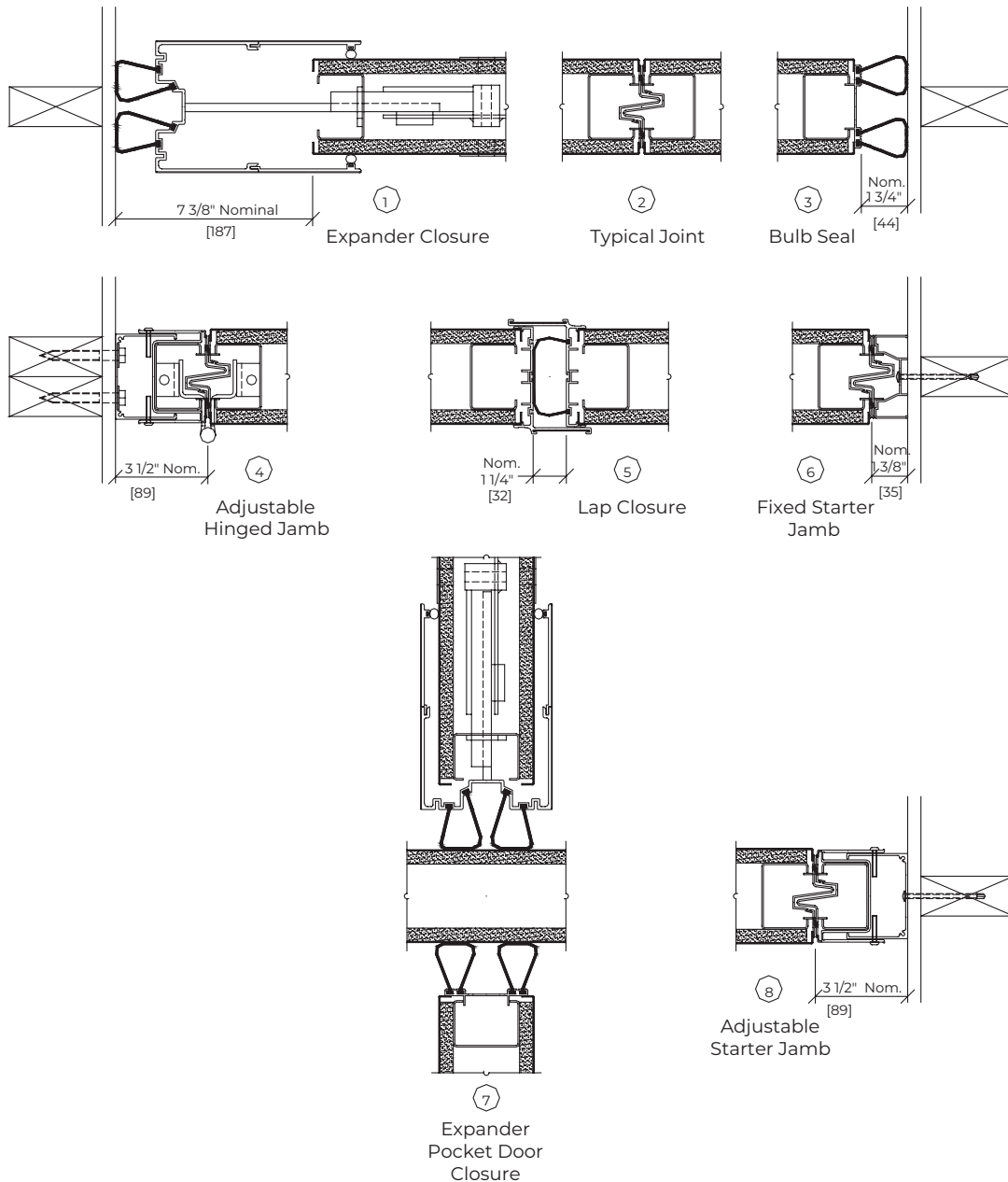



**ATLAS™ – Hinged, Paired Panels, 48, 43 STC**

SECTION 10 22 39 FOLDING PANEL PARTITIONS  
 SECTION 10 22 39.13 FOLDING GLASS-PANEL PARTITIONS

**HORIZONTAL CAP-TYPE VERTICAL ASTRAGAL DETAILS**

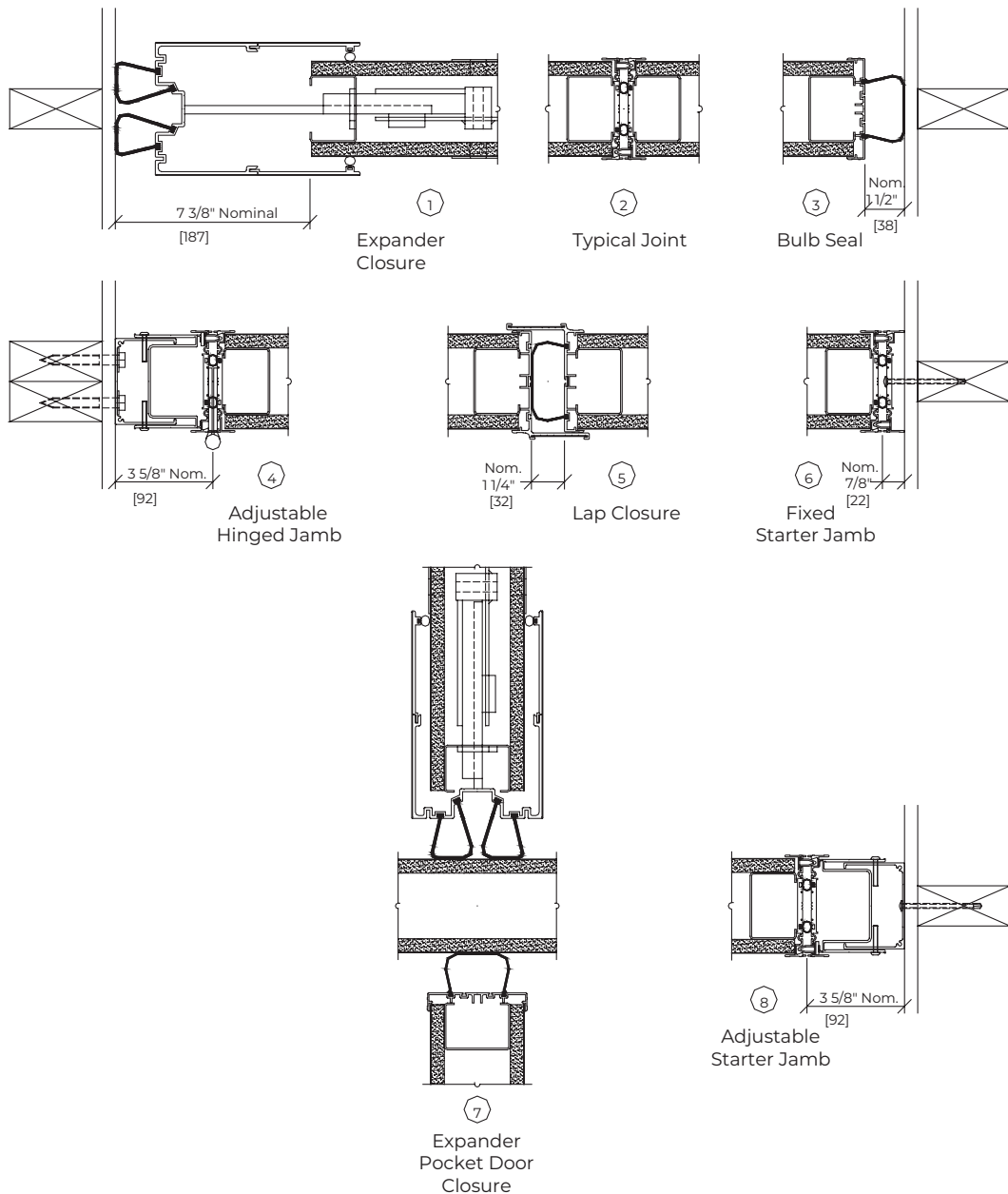



### ATLAS™ – Hinged, Paired Panels, 48, 43 STC

SECTION 10 22 39 FOLDING PANEL PARTITIONS  
SECTION 10 22 39.13 FOLDING GLASS-PANEL PARTITIONS

## VERTICAL DETAILS

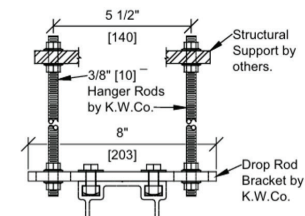
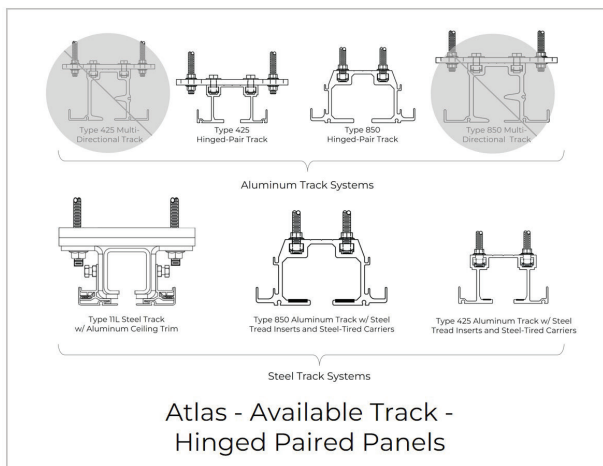

**Optional Drop Rod Bracket Mount**

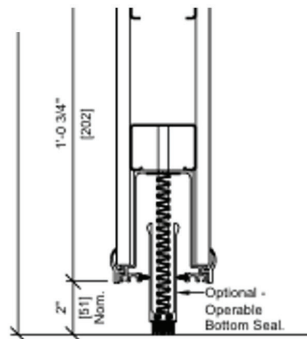

**Optional Operable Bottom Seal**

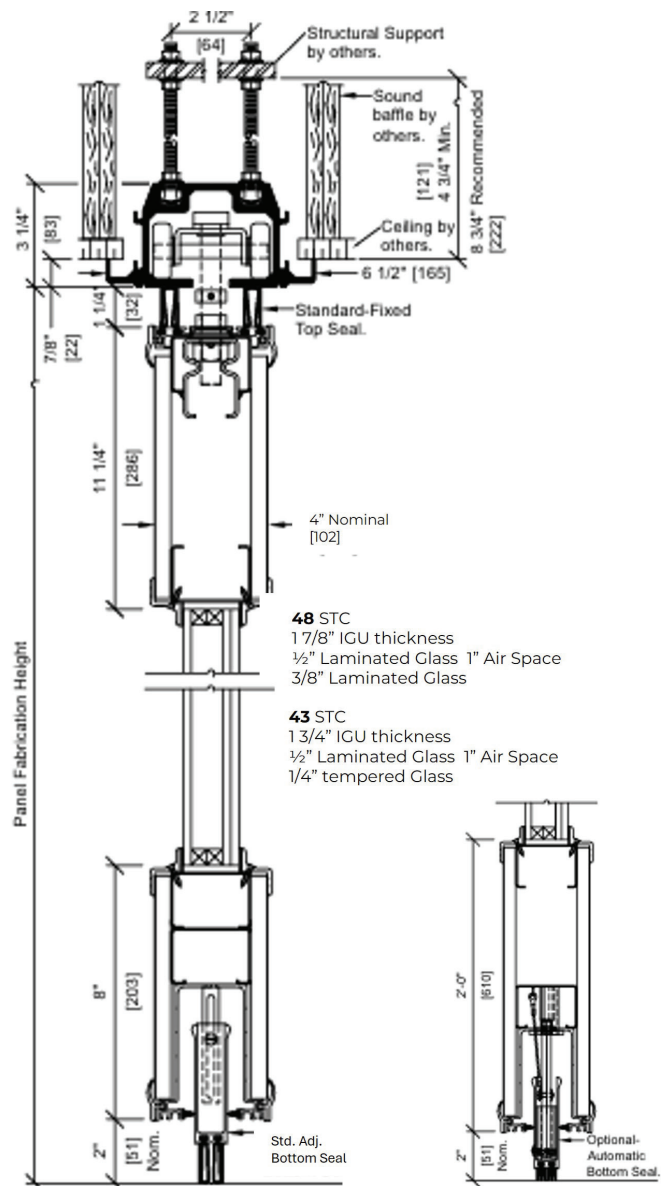

**850 Hinged Pairs Aluminum Track & Carriers**

**Optional Automatic Bottom Seal**