



2000 SERIES — Pocket Doors

SECTION 10 22 26 OPERABLE PARTITIONS
SECTION 10 22 39 FOLDING PANEL PARTITIONS



Overview

Pocket Door Types

- Bi-Fold Doors w/ Bulb Seal
- Single Door w/ Bulb Seal
- Single Door w/ Expander
- Double Doors w/ Lap Trim
- Double Doors w/ Expander
- Double Doors w/Expander & Interlock Switches [2050 model]

Operation

- Manual
- Electric: Safety Interlock disables 2050 electric operable wall operation when pocket doors are closed.

STC Options

A=Acoustic Substrate S=Steel Skin

- 52S 45A
- 50S 49A
- 42A 50A

Panel Finishes

- Vinyl High Pressure Laminate
 - Fabric Wood Veneer
 - Carpet Customer Supplied*
 - Digitally Printed Steel Skin
- * Material Subject to Kwik-Wall approval

Vertical Panel Joints

- Trimless
- Capped Trim

Top Seals

- Fixed
- Operable

Bottom Seals

- Fixed Automatic
- Adjustable Fixed Extended
- Operable

Security Hardware Options

- Keyed Cylinder Lock with adjustable concealed vertical rod interfacing with strike plate attached to finished floor.
- Master Keyed Cylinder Lock (optional), furnished by others and installed by KWIK-WALL as noted on submittal shop drawings.

KWIK-WALL's **2000 Series Pocket Doors** close off your operable wall storage area when panels are not in use. Constructed with the same materials as our 2000 Series operable wall panels, **2000 Series** pocket doors hide the operable wall panels and can serve as the perimeter wall for your final closure to seal against. In very wide openings, sealing to the face of the pocket door can eliminate panels without compromising the acoustic integrity of your operable wall.

Series **2000** Pocket Doors are 3" [76.2] thick, manufactured of a durable roll-formed steel frame, with steel skins for maximum durability and sound control.



2000 Series Panel Weights

STC	lbs./sq.ft.	Kg/m ²
52S	9.2 lbs./sq. ft.	[44.9 kg/m ²]
50S	8.6 lbs./sq. ft.	[41.9 kg/m ²]
42A	6.5 lbs./sq. ft.	[36.6 kg/m ²]
45A	7.5 lbs./sq. ft.	[36.6 kg/m ²]
49A	9.0 lbs./sq. ft.	[43.9 kg/m ²]
50A	9.0 lbs./sq. ft.	[43.9 kg/m ²]



2000 SERIES
More Information



2000 SERIES — Pocket Doors

SECTION 10 22 26 OPERABLE PARTITIONS

SECTION 10 22 39 FOLDING PANEL PARTITIONS



PART 1 – GENERAL SPECIFICATIONS

1.01 WORK INCLUDED

- A. Pocket Door(s) shall be furnished, installed, and serviced by operable wall manufacturer's authorized distributor, in compliance with the architectural drawings and specifications contained herein.

1.02 RELATED WORK

- A. Insulation: Sound insulation and baffles for the plenum area above the pocket door(s), under the permanent floor, inside air ducts passing over or around the pocket door(s), and in permanent walls adjoining the pocket door(s) shall be by others, in accordance with ASTM E 557.
- B. Opening Preparation: Proper and complete preparation of the pocket door opening shall be by others in accordance with ASTM E 557, and shall include floor leveling; plumbness of adjoining permanent walls; substrate and/or ceiling tile enclosures; and the painting and finishing of trim and other materials adjoining the head and jamb areas of the pocket door(s). Any permanent wall(s) receiving an adjustable hinged jamb will require internal structural blocking to secure the jamb to the permanent wall. Refer to the shop drawings for additional details.

1.03 SYSTEM DESCRIPTION

- A. The pocket door(s) shall consist of Individual Panel(s) or two (2) panels hinged together that are manually operated and hinged permanently and directly to a structural wall surface.
- B. The pocket door(s) shall consist of acoustically rated panels constructed of the same panel construction as the operable wall panel construction options.

1.04 QUALITY ASSURANCE

- A. The pocket door(s) panel construction and finish materials shall consist of Class A-rated materials (except as noted, under "Finishes" Part 2 – Products) in accordance with ASTM E84.
- B. The pocket door(s) shall be installed by the manufacturer's authorized distributor in accordance with ASTM E 557.

1.05 REFERENCES

- A. ASTM E 557: Architectural Application and Installation of Operable Partitions.
- B. ASTM E 84: Surface Burning Characteristics of Building Materials.
- C. ASTM A 653: Specification for General Requirements for Steel Sheet, Alloy-Coated (Galvannealed) by the Hot Dip Process.
- D. ASTM C 423: Standard Test Method for Sound Absorption and Sound Absorption Coefficients by the Reverberation Room Method.

- E. CCC-W-408A: Federal Specification which applies to Vinyl Coated Wall Coverings.
- F. CFFA-W-101-D: Chemical Fabrics and Film Association Quality Standard for Vinyl Coated Fabric Wall Coverings.

1.06 SUBMITTALS

- A. Manufacturer shall provide written technical information and related detail drawings, which demonstrate that the products comply with contract documents for each type of pocket door(s) specified.
- B. Manufacturer shall provide detailed engineering drawings featuring panel elevation, horizontal, and vertical details as required.
- C. Manufacturer shall provide written instructions specifying the proper operation and maintenance of the pocket door(s) system.
- D. Manufacturer shall provide a color selector demonstrating the manufacturer's selections of the specified finish material. Samples shall consist of actual swatches of the specified finish material.

1.07 DELIVERY, STORAGE, AND HANDLING

- A. Pocket Door(s) shall be individually wrapped in a protective plastic covering to keep panels clean during delivery, storage, and handling.
- B. Pocket Door(s) shall be stored on edge and above the floor on cushioned blocking in a dry and ventilated area, protected from humidity and temperature extremes.

1.08 SEQUENCING / SCHEDULING

- A. Pocket Door(s) Installation: Pocket Door(s) installation shall occur after fixed wall substrate construction is properly and completely installed by others, as required to protect panels from ongoing adjacent construction.

1.09 WARRANTY

Manufacturer shall warrant each operable wall panel and its component parts to be free from defects in material and workmanship for a period of ten (10) years from the shipping date to the original purchaser, when installed by an authorized KWIK-WALL distributor. KWIK-WALL also warrants the fixed top seals to be free from defects in material and workmanship for a period of ten (10) years. (Contact your local KWIK-WALL Distributor or KWIK-WALL Company for complete warranty information.)



2000 SERIES — Pocket Doors

SECTION 10 22 26 OPERABLE PARTITIONS

SECTION 10 22 39 FOLDING PANEL PARTITIONS



PART 2 – PRODUCT SPECIFICATIONS

2.01 ACCEPTABLE MANUFACTURER

- A. Pocket Doors shall be Series 2000, manufactured by KWIK-WALL Company.

2.02 PANEL CONSTRUCTION

- A. Panel Dimensions: Standard panel dimension shall be a nominal 3" [76] thick.
- B. Panel Frame: Vertical steel frame members shall be minimum 18-gauge galvanized steel, horizontal top cross member shall be minimum 12-gauge galvanized steel, which meets or exceeds ASTM A 653 requirements. Frame shall be all-welded construction with steel corner supports and cross-bracing reinforcements. Panel frame shall be Class A rated in accordance with ASTM E 84.
- C. Panel Skins: Panel skins shall be Class A rated (except Wood Veneer and High Pressure Laminate) in accordance with ASTM E 84. Panel skin material shall consist of (select):
1. Acoustical Substrate: consisting of structural acoustical substrate pressure laminated to both sides of the steel frame to form a rigid, unitized, and structural panel.
 2. Steel Skins: consisting of minimum 22-gauge tension-lev-eled galvanized steel, pressure laminated to a structural acoustical backer and mechanically joined to the steel frame to form a rigid, unitized and structural panel.
 3. Wood Veneer: consisting of particle board core covered with wood veneer and pressure laminated to both sides of the steel frame to form a rigid, unitized, and structural panel.
 4. High-Pressure Laminate: consisting of gypsum board core covered with general-purpose plastic laminate and Phenolic backer sheet, which is pressure laminated to both sides of the steel frame to form a rigid, unitized, and structural panel.

*Wood Veneer or High-Pressure Laminate is only available with Acoustical Substrate Construction.

- D. Panel Hinges: Panel hinges shall be architectural grade, full-leaf butt hinges. Hinges shall be attached to the steel frame of the panel(s) and reinforced with a steel backer plate.
- E. Panel Weight: Maximum panel weight shall be 6.5 – 9.2. / ft.2 (32 – 45 kg / m2) depending on size and options selected.

2.03 OPERATION

- A. Operation shall consist of an individual panel or two panels hinged together and hinged to an adjustable jamb. Pocket doors shall be manually operated and capable of swinging 180° to allow sufficient clearance for the operable wall panels. One

(1) pocket door panel shall contain a flush pull handle and a surface-mounted footbolt with strike plate.

2.04 FINISHES

- A. Finish Material Type: Pocket Door finish material shall be Class A (except wood veneer and high-pressure laminate) rated in accordance with ASTM E 84, consisting of (select):
1. Vinyl: consisting of Type II, reinforced vinyl weighing 21 oz. / lin. yd. (651 g / lin. m). Vinyl shall meet or exceed CCC-W-408A and CFFA-W-101-D quality standards.
 2. Fabric: consisting of fade and tear resistant fabric that resists water-based stains weighing 13 oz. / lin. yd. (403 g / lin. m).
 3. Standard Carpet: consisting of acoustically absorbent, non-woven needle punch fibers fused to prevent fraying and unraveling of material weighing 28.5 oz. / lin. yd. (884 g / lin. m). Basics Carpet shall achieve a minimum NRC (Noise Reduction Coefficient) rating of .25 (applied over gypsum substrate) in accordance with ASTM C 423.
 4. Upgrade Carpet: consisting of acoustically absorbent, non-woven needle punch fibers fused to prevent fraying and unraveling of material weighing 23 oz. / lin. yd. (713 g / lin. m). Upgrade Carpet shall achieve a minimum NRC (Noise Reduction Coefficient) rating of .20 (applied over gypsum substrate) in accordance with ASTM C 423.
 5. Wood Veneer: consisting of unfinished flat cut wood veneer laminated to 1/2" [12.7] thick particle board core. Veneer shall be book / running matched within a panel and vertically edge-banded (if trimless astragals are specified).
(Notes: Optional Class "A" rated particle board is available. Acoustical substrate STC ratings apply for Wood Veneer panel construction.)
 6. High-Pressure Laminate: consisting of gypsum board core covered with general-purpose plastic laminate and Phenolic backer sheet, which is pressure laminated to both sides of the steel frame to form a rigid, unitized, and structural panel.
(Note: Acoustical substrate STC ratings apply for High Pressure Laminate panel construction.)
 7. Digitally Printed Steel Skins: Seven-ply construction comprised of melted, rolled, coated, or printed layers. (52 and 50 STC steel skin panel construction only)
 8. Optional Unfinished: consisting of panels with exposed acoustical substrate or steel skins for field-applied wall covering or painting.
- B. Finish Material Supplier: Finish material shall be (select):
1. Standard Factory Supplied: from manufacturer's standard selection of finish materials, as specified.



2000 SERIES — Pocket Doors

SECTION 10 22 26 OPERABLE PARTITIONS

SECTION 10 22 39 FOLDING PANEL PARTITIONS



2. Optional Customer Supplied: from customer's selection of finish material, by others, and as approved by KWIK-WALL Company.
- C. Finish Material Application: Finish material shall be (select):
 1. Standard Factory Applied: by operable wall manufacturer. Customer-supplied finish material samples must be submitted to the manufacturer for testing and approval, prior to acceptance and application.
 2. Optional Field Applied: by others.

2.06 PERIMETER TRIM AND SEALS

- A. Vertical Trim and Seals: Panels shall have vertical astragals containing flexible vinyl seals and incorporate reversible tongue-and-groove-type configurations for positive interlocking with adjacent panels. Vertical astragal type shall be (select):
 1. Trimless Astragal: consisting of an aluminum extrusion with tongue-and-groove-type vertical astragals. Vertical trim shall not be permitted on the panel faces, resulting in a minimal groove appearance between adjacent panels.
 2. Cap-type Astragal: consisting of an aluminum extrusion with tongue-and-groove-type vertical astragals for encapsulating and protecting the finish material and substrate along the vertical edge of the panel.
- B. Horizontal Top Trim and Seals: Top seals shall consist of flexible vinyl sweep seals installed on both sides of the panel. The seals shall consist of a compressed bulb between two (2) fingers of vinyl. Top seal type shall be fixed, continuous-contact flexible vinyl, sealing against the pocket door header trim.
- C. Horizontal Bottom Trim and Seals: Bottom seals shall consist of a single finger of flexible vinyl sweep seal installed on both sides of the panel. Bottom seal type shall be fixed, consisting of continuous-contact flexible vinyl, sealing against various floor surfaces.
- D. Pocket Door Header Trim: Header trim shall be extruded from aluminum alloy, which prohibits deterioration caused by rust or corrosion. Header Trim shall be attached to the finished ceiling directly above the pocket door(s), providing a flush surface for the fixed top seals to contact.
- E. Horizontal and Vertical Panel Trim: All exposed panel trim and hinges shall be of one (1) similar color as selected from the manufacturer's standard colors.

2.07 POCKET DOOR CLOSURES

- A. Pocket Door Types: Each pocket door configuration shall be hinged to an adjustable jamb consisting of an aluminum extrusion which is permanently mounted to a structural wall surface and is field-adjustable to compensate for out-of-plumb conditions of the fixed wall. The adjustable jamb shall incor-

porate a tongue-and-groove-type vertical astragal for positive interlocking with a pocket door panel. To stabilize the pocket door(s) a surface-mounted footbolt shall be furnished by the operable wall manufacturer and installed by others in the field. The pocket door configuration shall be (select):

1. Bi-Fold Doors w/ Bulb Seal: consisting of a pair of panels hinged together and hinged to an adjustable jamb. The lead panel shall contain flexible vinyl bulb seals installed along the vertical edge of the lead panel for positive compression against a rigid wall surface. A roller support caster located at the bottom of one (1) panel shall be included to provide additional support for the pocket doors. (Note: This type of pocket door is normally used with a Model 2020 operable wall system utilizing a perpendicular stack unit.)
2. Single Door w/ Bulb Seal: consisting of a single panel hinged to an adjustable jamb. The lead edge of the panel shall contain flexible vinyl bulb seals installed along the vertical edge, creating a positive compression against a rigid wall surface. (Note: This type of pocket door is normally used with a Model 2020 operable wall system utilizing a parallel or remote stack unit.)
3. Single Door w/ Expander: consisting of a single panel hinged to an adjustable jamb. The lead edge of the panel shall contain an expander mechanism with a nominal 5" [127] of travel, activated from the face of the panel using a removable wrench as supplied by manufacturer. (Note: This type of pocket door is normally used with a Model 2020 operable wall system utilizing a parallel or remote stack unit.)
4. Double Doors w/ Lap Trim: consisting of two (2) individual panels with each panel being hinged to an adjustable jamb. The lead edge of each panel shall contain a lap-type extrusion that overlaps with the other one, creating a shiplap joint. (Note: This type of pocket door is normally used with a Model 2030 operable wall system utilizing a center-type stack arrangement or Model 2020 remote stack unit.)
5. Double Doors w/ Expander: consisting of two (2) individual panels with each panel being hinged to an adjustable jamb. The lead edge of one (1) panel shall contain an expander mechanism with a nominal 5" [127] of travel, activated from the face of the panel using a removable wrench as supplied by manufacturer. The lead edge of the adjacent panel shall contain flexible vinyl bulb seals installed along the vertical edge for positive compression against the face of the operable wall panel. (Note: This type of pocket door is normally used with a Model 2030 operable wall system utilizing a center-type stack



2000 SERIES — Pocket Doors

SECTION 10 22 26 OPERABLE PARTITIONS

SECTION 10 22 39 FOLDING PANEL PARTITIONS



arrangement.)

Note: Pocket door(s) require additional depth and width to the stack area.

2.08 ACOUSTICAL PERFORMANCE

- A. Certification: The pocket door(s) shall consist of acoustically rated panels constructed with the same panel construction as the operable wall panel construction options, unless called out on shop drawings.

2.09 POCKET DOOR ACCESSORY

- A. Accessory includes Keyed Cylinder Lock with adjustable concealed vertical rod interfacing with strike plate attached to finished floor. Lock unit shall be capable of receiving a master cylinder, furnished by others and installed by the operable wall manufacturer as noted on submitted shop drawings.

PART 3 – EXECUTION

3.01 INSPECTION

- A. Proper and complete preparation of the pocket door opening shall be by others in accordance with the architectural drawings, manufacturer's shop drawings and ASTM E 557. Any deviation of the actual opening from these specifications shall be called to the attention of the architect, prior to the installation of the pocket door(s).
- B. Deficiencies in the pocket door opening shall be corrected by others prior to installation of the pocket door(s).

3.02 INSTALLATION

- A. The pocket door(s) shall be installed by manufacturer's authorized distributor.
- B. The pocket door(s) shall be installed in accordance with manufacturer's written instructions, shop drawings and ASTM E 557 installation guidelines.

3.03 ADJUSTING AND CLEANING

- A. The pocket door(s) shall be adjusted and cleaned in accordance with manufacturer's written instructions.

3.04 PROTECTION

- A. The pocket door(s) shall be stored in the "extended" position prior to acceptance by the owner's representative.

3.05 DEMONSTRATION

- A. The operable wall manufacturer's authorized distributor shall demonstrate proper operation and explain proper and necessary maintenance requirements of the pocket door(s) to the owner's representative.

For additional information contact:

KWIK-WALL Company
4650 Industrial Ave.
Springfield, Illinois 62703

Phone: 217-522-5553 or 800-280-5945 (United States and Canada only)
Fax: 217-522-1170 or 800-290-5945 (United States and Canada only)
Website: www.kwik-wall.com
Email: info@kwik-wall.com

Note: Due to ongoing research and development, product specifications may vary.
5.2026



2000 SERIES — Pocket Doors
SECTION 10 22 26 OPERABLE PARTITIONS
SECTION 10 22 39 FOLDING PANEL PARTITIONS



FINAL JAMB CLOSURES

Bi-Fold Doors with Bulb Seal

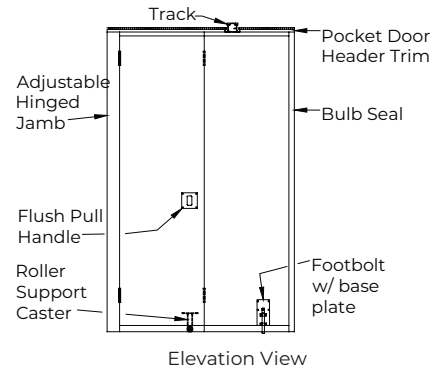
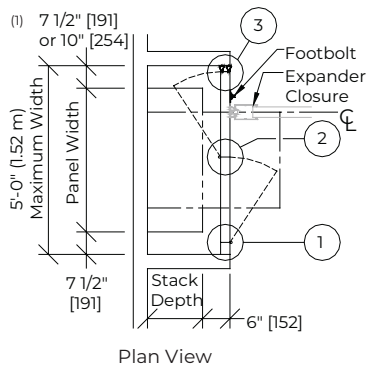

Single Door with Bulb Seal

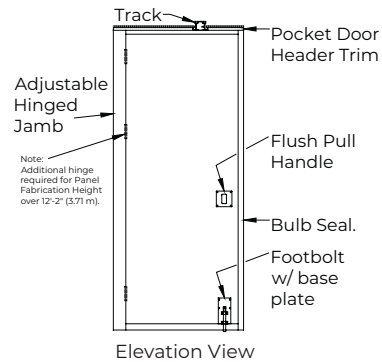
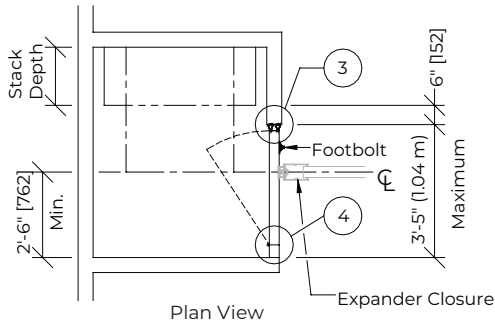

Single Door with Expander

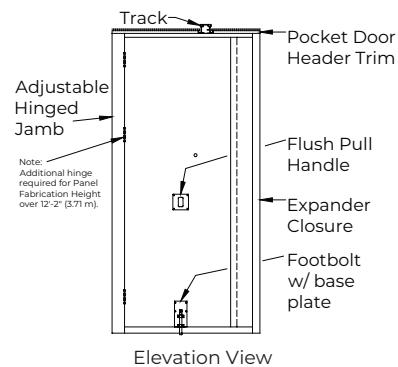
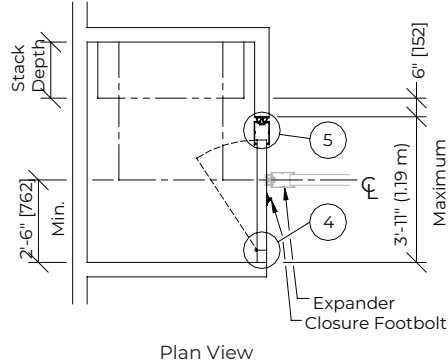



2000 SERIES — Pocket Doors

SECTION 10 22 26 OPERABLE PARTITIONS
SECTION 10 22 39 FOLDING PANEL PARTITIONS



FINAL JAMB CLOSURES

Double Doors with Expander

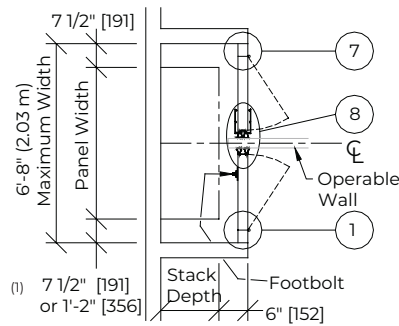

Plan View

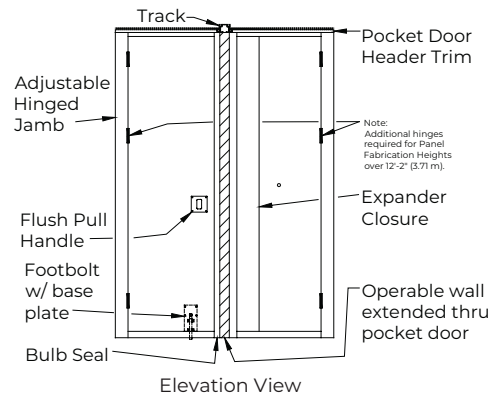

Elevation View

Double Doors with Lap Trim

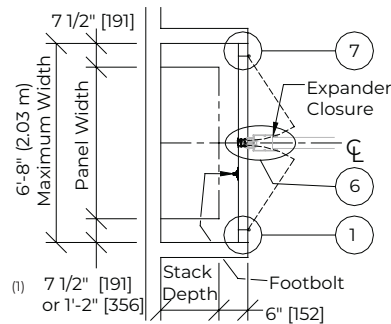

Plan View

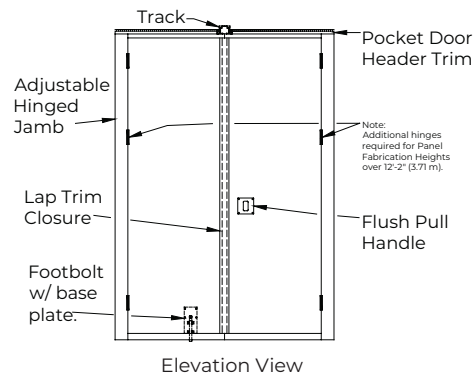

Elevation View

- | | |
|---------------------------|---------------------------------|
| 1. Adjustable Hinged Jamb | 5. Expander Closure |
| 2. Hinged Joint | 6. Lap Closure |
| 3. Bulb Seal | 7. Adjustable Hinged Jamb |
| 4. Adjustable Hinged Jamb | 8. Expander / Bulb Seal Closure |

Notes:

- Operable wall systems containing automatic bottom seals require additional pocket width.
- KWIK-WALL has designed five (5) types of pocket doors that work with our operable wall configurations, if your project requires a custom designed pocket door please contact your local distributor.



2000 SERIES — Pocket Doors

SECTION 10 22 26 OPERABLE PARTITIONS
SECTION 10 22 39 FOLDING PANEL PARTITIONS



HORIZONTAL TRIMLESS DETAILS

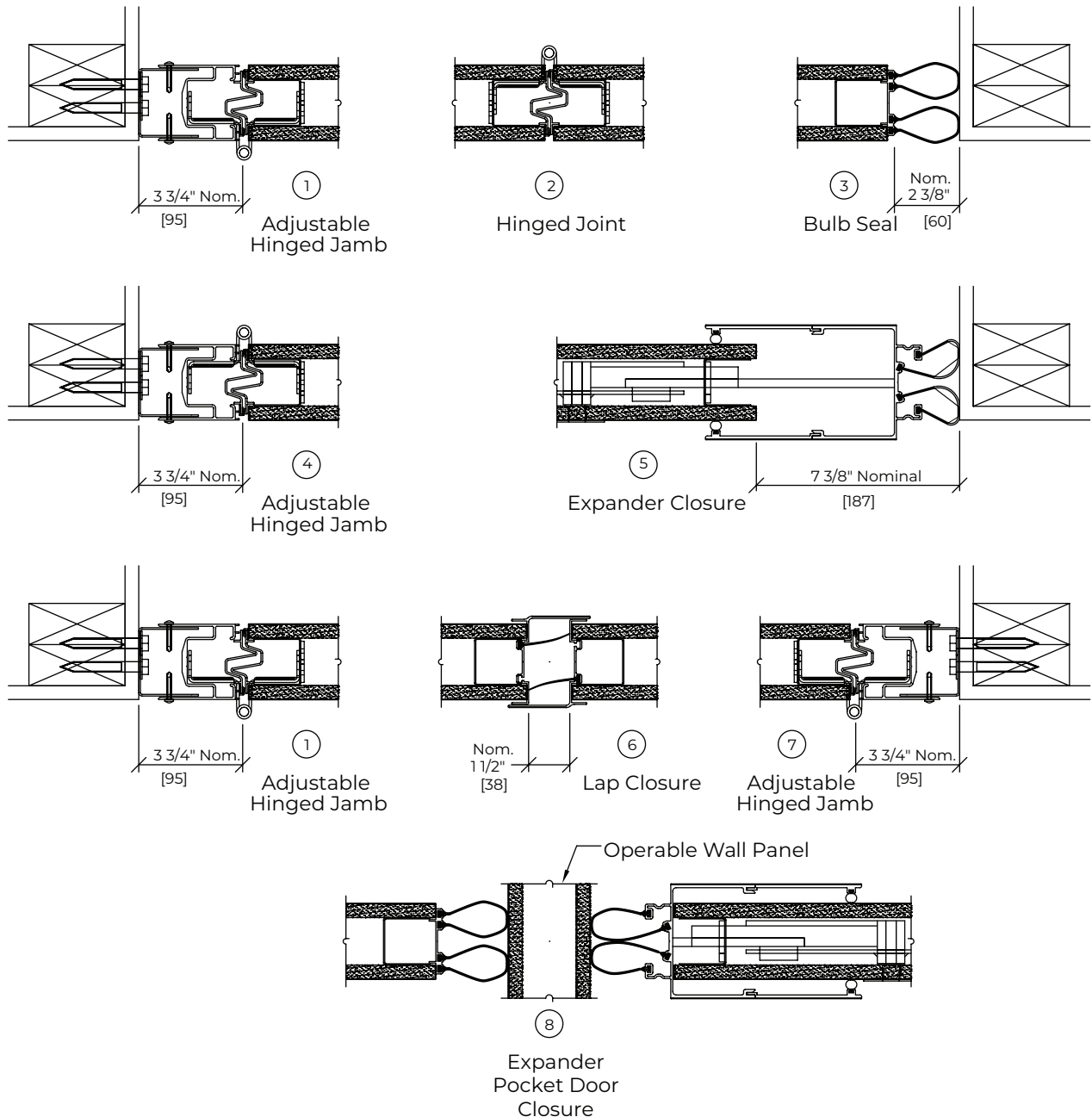



2000 SERIES — Pocket Doors

SECTION 10 22 26 OPERABLE PARTITIONS
SECTION 10 22 39 FOLDING PANEL PARTITIONS



HORIZONTAL CAP-TYPE VERTICAL ASTRAGAL DETAILS

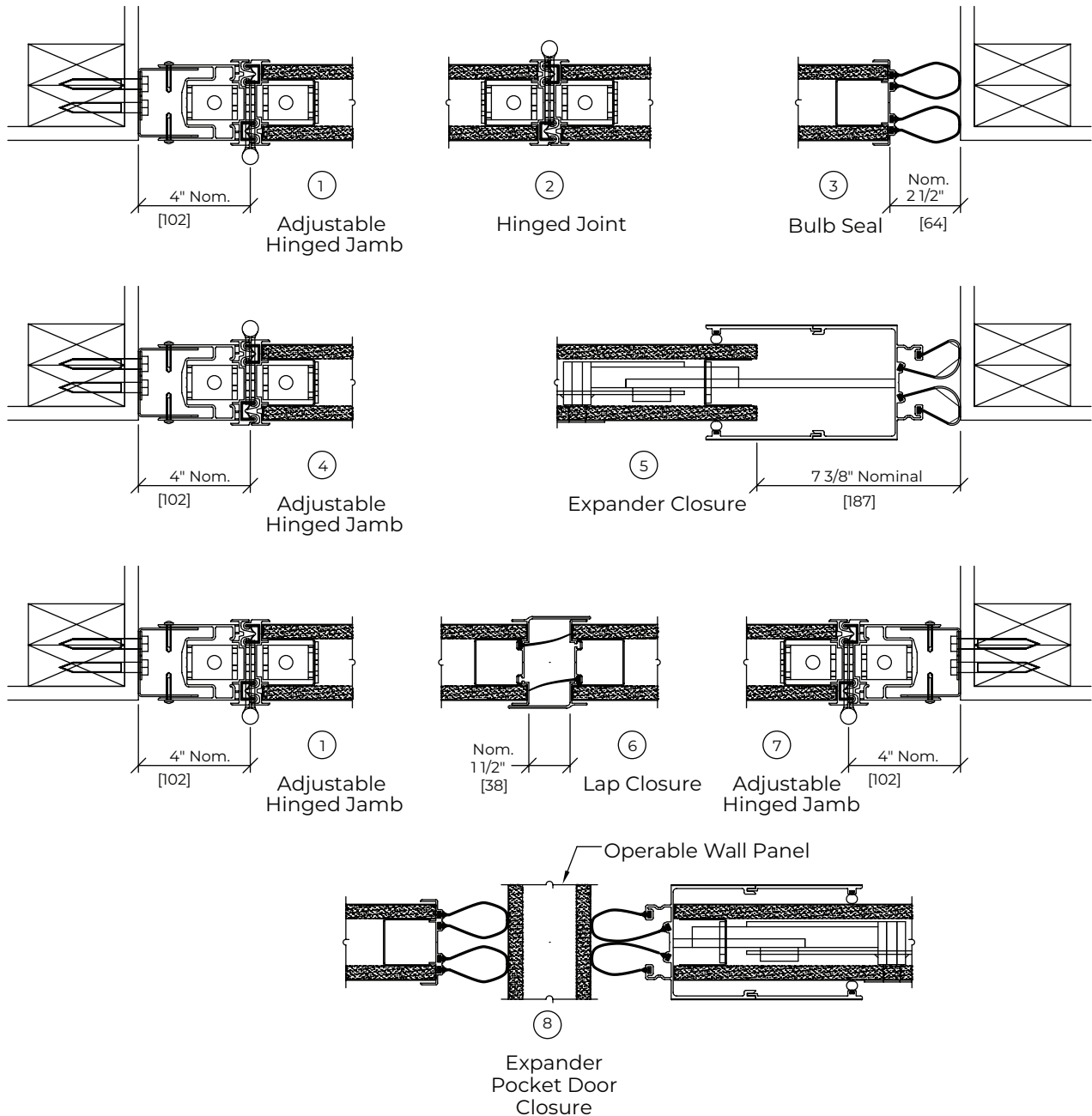



2000 SERIES — Pocket Doors

SECTION 10 22 26 OPERABLE PARTITIONS
SECTION 10 22 39 FOLDING PANEL PARTITIONS



VERTICAL DETAILS

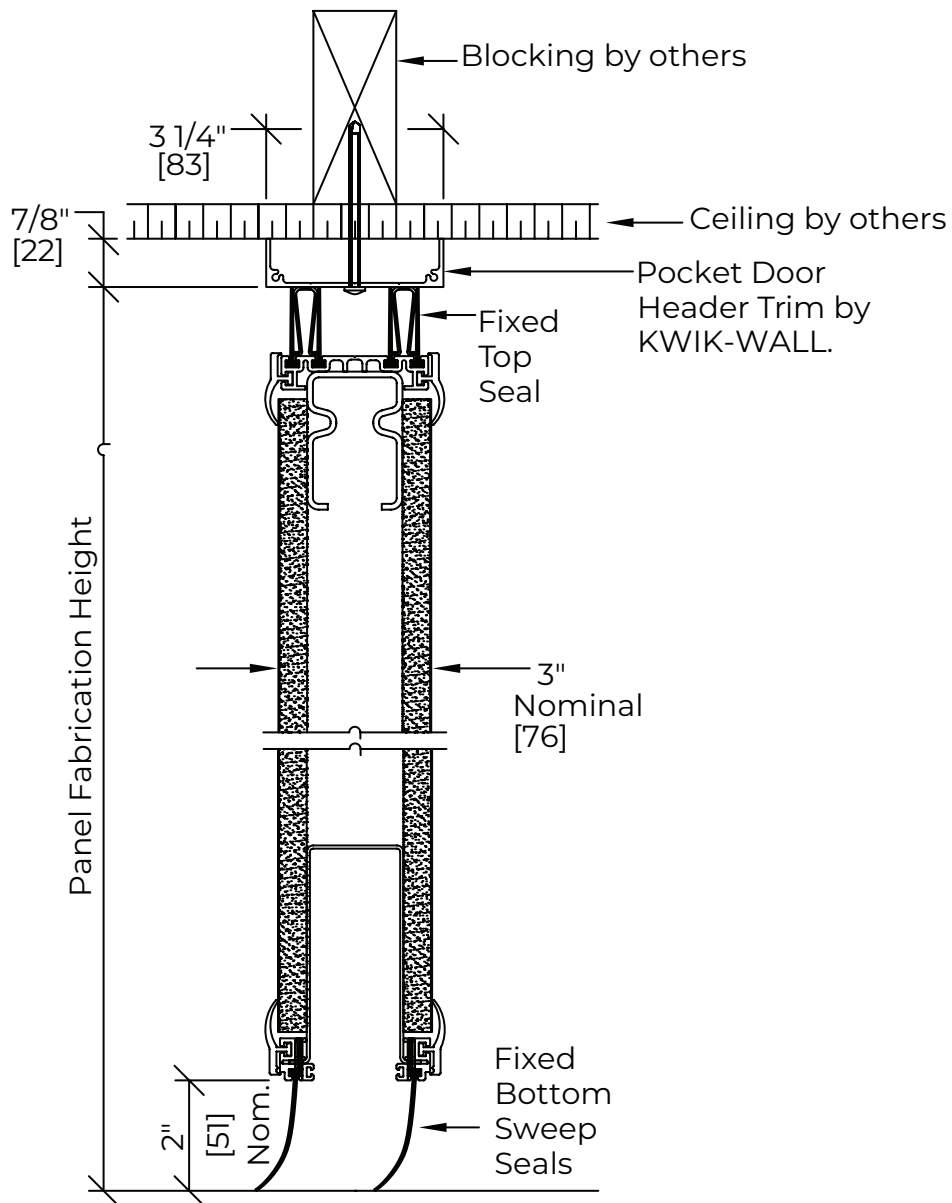

Single or Double Pocket Door



2000 SERIES — Pocket Doors

SECTION 10 22 26 OPERABLE PARTITIONS
SECTION 10 22 39 FOLDING PANEL PARTITIONS



VERTICAL DETAILS

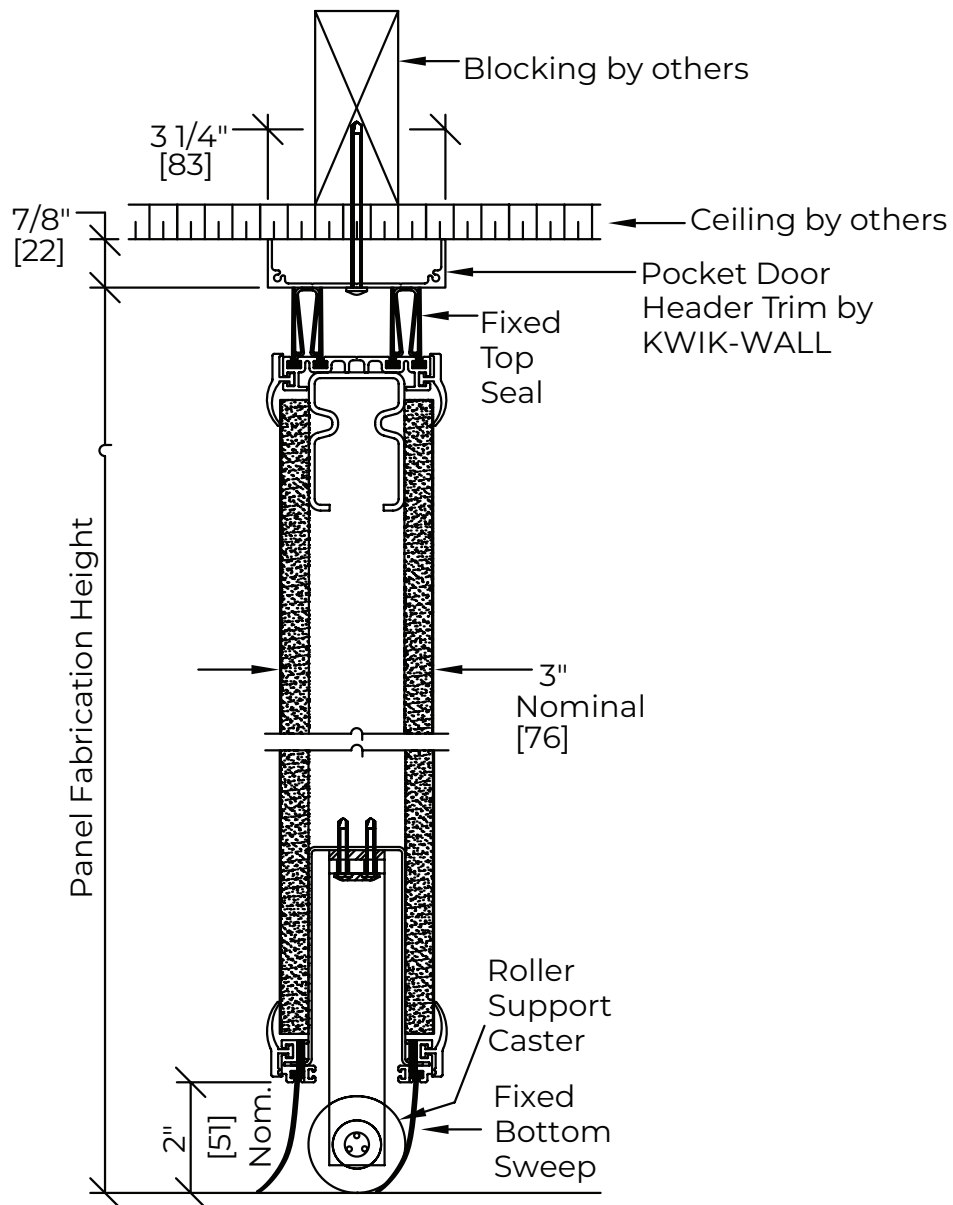

Bi-Fold Pocket Door



2000 SERIES — Pocket Doors

SECTION 10 22 26 OPERABLE PARTITIONS
 SECTION 10 22 39 FOLDING PANEL PARTITIONS



- POCKET DOOR TYPES
- POCKET DOOR WIDTH LIMITS
- PANEL CONSTRUCTION
- STC OPTIONS
- OPENING HEIGHT LIMITS

Series 2000 Pocket Doors			
Pocket Door Type	Maximum Pocket Door Opening	3" Pocket Door Construction [S] Steel Skin / STC [A] Acoustic Substrate / STC	Maximum Pocket Door Height
Bi-Fold w/ Bulb Seal	5'-0" [1.52 m]	S - 52,50 STC A - 42,45,49,50 STC	12'-2" [3.71 m]
Double w/ Expander	6'-8" [2.03 m]	S - 52,50 STC A - 42,45,49,50 STC	16'-2" [4.93 m]
Double w/ Lap Trim	6'-8" [2.03 m]	S - 52,50 STC A - 42,45,49,50 STC	16'-2" [4.93 m]
Single w/ Bulb Seal	3'-5" [1.04 m]	S - 52,50 STC A - 42,45,49,50 STC	16'-2" [4.93 m]
Single w/ Expander	3'-11" [1.19 m]	S - 52,50 STC A - 42,45,49,50 STC	16'-2" [4.93 m]

Notes:

- Finishes requiring acoustic substrate construction: High Pressure Laminate & Wood Veneer.
- Pocket Door STC Rating will default to Operable Wall Panel STC Ratings unless noted on Shop Drawing.
- Please refer to: ASTM E 557 "Standard Guide for the Installation of Operable Partitions".