



## MODEL 2050 — Continuously-Hinged Electric Panels

SECTION 10 22 26 OPERABLE PARTITIONS  
SECTION 10 22 39 FOLDING PANEL PARTITIONS



### Overview

#### Panel Type

- Individual Panels, Curve and Diverter
- Individual Panels, Multi-Directional
- Hinged-Paired
- Continuously-Hinged

#### Partition Operation

- Manual
- Electric

#### Stacking Configurations

- Centerline
- Offset
- Remote
- Bi-Parting

#### STC Options

A=Acoustic Substrate S=Steel Skin

- 52S       45A
- 50S       49A
- 42A       50A

#### Panel Finishes

- Vinyl       High Pressure Laminate
  - Fabric       Wood Veneer
  - Carpet       Customer Supplied\*
  - Digitally Printed Steel Skin
- \* Material Subject to Kwik-Wall approval

#### Vertical Panel Joints

- Trimless
- Capped Trim

#### Top Seals

- Fixed
- Operable

#### Bottom Seals

- Fixed       Automatic
- Adjustable Fixed       Extended
- Operable

#### Available Options

Storage pocket doors; ADA Pass Doors – (single, concealed door closures & exit signs); dry marker surfaces; insulated glass unit inserts; tack surfaces.

**KWIK-WALL's Model 2050** – features electric operation for fully automatic setup. With centerline support, continuously-hinged electric operable walls are ideally suited for large, tall openings for straight-run room division applications up to 14'-2" [4318] tall. With STC options from 42-52, Series 2000 operable walls offer industry-leading premium sound control.

**Model 2050** construction features panels that are 3" thick [76.2] thick, manufactured of a durable roll-formed steel frame with steel skins, or with acoustic substrate to form a rigid, unitized and structural panel for maximum sound control and durability. Optional insulated glass units can be added.



2000 Series Panel Weights

STC	lbs./sq.ft.	Kg/m2
52S	9.2 lbs./sq. ft.	[44.9 kg/m2]
50S	8.6 lbs./sq. ft.	[41.9 kg/m2]
42A	6.5 lbs./sq. ft.	[36.6 kg/m2]
45A	7.5 lbs./sq. ft.	[36.6 kg/m2]
49A	9.0 lbs./sq. ft.	[43.9 kg/m2]
50A	9.0 lbs./sq. ft.	[43.9 kg/m2]



2050

More Information



### MODEL 2050 — Continuously-Hinged Electric Panels

#### SECTION 10 22 26 OPERABLE PARTITIONS SECTION 10 22 39 FOLDING PANEL PARTITIONS



#### PART 1 – GENERAL SPECIFICATIONS

##### 1.01 WORK INCLUDED

- A. Operable Wall System shall be furnished, installed, and serviced by wall manufacturer's authorized distributor, in compliance with the architectural drawings and specifications contained herein.

##### 1.02 RELATED WORK

- A. Structural Support: Structural support system required for suspending the operable wall shall be designed, installed, and pre-punched by others, in accordance with ASTM E 557 and manufacturer's shop drawings.
- B. Insulation: Sound insulation and baffles for the plenum area above the track system, under the permanent floor, inside air ducts passing over or around the operable wall, and in permanent walls adjoining the operable wall system shall be by others, in accordance with ASTM E 557.
- C. Opening Preparation: Proper and complete preparation of the operable wall system opening shall be by others in accordance with ASTM E 557, and shall include floor leveling; plumbness of adjoining permanent walls; substrate and/or ceiling tile enclosures for the track system; and the painting and finishing of trim and other materials adjoining the head and jamb areas of the operable wall.

##### 1.03 SYSTEM DESCRIPTION

- A. The operable wall system shall consist of continuously hinged panels that are electrically operated, featuring panels hinged together in a continuous panel train.
- B. The operable wall system shall consist of acoustically rated panels tested in accordance with ASTM E 90 and ASTM E 413 test procedures and shall have achieved a STC rating as specified herein (see "Acoustical Performance" article listed under Part 2 – Products).

##### 1.04 QUALITY ASSURANCE

- A. The operable wall shall have been tested in an independent acoustical testing laboratory in accordance with ASTM E 90 and ASTM E 413 test procedures.
- B. The operable wall panel construction and finish materials shall consist of Class A rated materials in accordance with ASTM E 84.
- C. The operable wall shall be installed by the manufacturer's authorized distributor in accordance with ASTM E 557.

##### 1.05 REFERENCES

- A. ASTM E 90: Laboratory Measurement of Airborne-Sound Transmission Loss of Building Partitions.

- B. ASTM E 413: Determination of Sound Transmission Class (STC).
- C. ASTM E 557: Architectural Application and Installation of Operable Partitions.
- D. ASTM E 84: Surface Burning Characteristics of Building Materials.
- E. ASTM A 653: Specification for General Requirements for Steel Sheet, Alloy-Coated (Galvannealed) by the Hot Dip Process.
- F. ASTM C 423: Standard Test Method for Sound Absorption and Sound Absorption Coefficients by the Reverberation Room Method.
- G. CCC-W-408A: Federal Specification which applies to Vinyl Coated Wall Coverings.
- H. CFFA-W-101-D: Chemical Fabrics and Film Association Quality Standard for Vinyl Coated Fabric Wall Coverings.
- I. NFPA 70: Standard for the safe installation of electrical wiring and equipment.

##### 1.06 SUBMITTALS

- A. Manufacturer shall provide written technical information and related detail drawings, which demonstrate that the products comply with contract documents for each type of operable partition specified.
- B. Manufacturer shall provide detailed engineering drawings featuring track plan, panel elevation, horizontal and vertical details, wiring diagram, and beam punching template as required.
- C. Manufacturer shall provide a written test report of the independent acoustical testing laboratory certifying the attainment of the specified STC rating, upon request.
- D. Manufacturer shall provide written instructions specifying the proper operation and maintenance of the operable wall system.
- E. Manufacturer shall provide a color selector demonstrating the manufacturer's selections of the specified finish material. Samples shall consist of actual swatches of the specified finish material.

##### 1.07 DELIVERY, STORAGE AND HANDLING

- A. Panels shall be individually wrapped in a protective plastic covering to keep panels clean during delivery, storage and handling.
- B. Panels shall be stored on edge and above the floor on cushioned blocking in a dry and ventilated area, protected from humidity and temperature extremes.



### MODEL 2050 — Continuously-Hinged Electric Panels

#### SECTION 10 22 26 OPERABLE PARTITIONS SECTION 10 22 39 FOLDING PANEL PARTITIONS



#### 1.08 SEQUENCING / SCHEDULING

- A. Beam Punching: Manufacturer shall provide beam punching template drawing detailing the anchor locations for the suspended track system (as required for Drop Rod Mounting), as required for the fabrication and installation of structural overhead support by others.
- B. Track Installation: Scheduling of operable wall track installation shall occur after structural overhead support has been properly and completely fabricated and installed by others.
- C. Panel Installation: Operable wall panel installation shall occur after fixed wall substrate construction is properly and completely installed by others, as required to protect panels from ongoing adjacent construction.

#### 1.09 WARRANTY

- A. Manufacturer shall warrant each 2050 partition and its component parts to be free from defects in material and workmanship for a period of ten (10) years to the original purchaser, when installed by an authorized KWIK-WALL distributor. (Contact your local KWIK-WALL distributor or KWIK-WALL Company for complete warranty information.)

### PART 2 – PRODUCT SPECIFICATIONS

#### 2.01 ACCEPTABLE MANUFACTURER

- A. Operable walls shall be Series 2000, Model 2050 Continuously Hinged / Electric as manufactured by KWIK-WALL Company.

#### 2.02 PANEL CONSTRUCTION

- A. Panel Dimensions: Standard panel dimension shall be a nominal 3" [76.2] thick.
- B. Panel Frame: Steel frame shall be 18-gauge galvanized steel, which meets or exceeds ASTM A 653 requirements. Frame shall be all-welded construction with steel corner supports and cross-bracing reinforcement. Panel frame shall be Class A rated, fire retardant, non-combustible and non-corrosive in accordance with ASTM E 84.
- C. Panel Skins: Panel skins shall be Class A rated in accordance with ASTM E 84. Panel skin material shall consist of (select):
  1. Steel Skins: consisting of minimum 22-gauge tension-lev- eled galvanized steel, pressure laminated to a structural acoustical backer and mechanically joined to the steel frame to form a rigid, unitized, and structural panel.
  2. Acoustical Substrate: consisting of structural acoustical substrate, pressure-laminated and mechanically joined to both sides of the steel frame to form a rigid, unitized, and structural panel.

- D. Panel Hinges: Panel hinges shall be architectural grade, full-leaf butt hinges. Hinges shall be attached to steel frame utilizing a steel mounting bracket welded to frame.
- E. Panel Weight: Maximum panel weight shall be 6.5 – 9.2 lb. / ft.2 (32 – 45 kg / m2) depending on STC rating, size, and options selected.

#### 2.03 OPERATION

- A. Operation: Operation shall be Continuously Hinged / Electric, consisting of panels hinged together forming a continuous panel train. Panels shall be top-supported by one (1) carrier in every other panel, consisting of four (4) permanently lubricated, precision-ground ball-bearing polished steel wheels riding on a steel tread surface. Panels shall be operated between stacking location and installed position by an electric operator, which connects to lead panel by #50 roller chain. A manual override shall be included in the event of a power failure to allow the operable wall system to be manually operated.
- B. Drive System: Electric motor shall consist of (select):
  1. Standard Electric Motor: consisting of a 1 Horsepower (.746 kw), 115 volt, 1 Phase, 60 Hz capacitance wound motor.
  2. Optional Electric Motor: consisting of a 1 Horsepower (.746 kw), 208 volt, 3 Phase, 60 Hz capacitance wound motor.
- C. Activation of the operator shall be controlled by a two (2) position (low voltage) key switch to arm the system. Control of the operator shall consist of two (2) stations with extend and retract constant-pressure push-button switches. Switches shall be low voltage, wired in series, and located on opposite sides and ends of the partition. Electric operator shall include safety devices (limit switches) to automatically shut off the operator at the fully extended and fully retracted position. Operator shall be located at the opposite end of stack area, off center to the side of the partition. All electric operator components shall be modularized for easy replacement in the field without removing the surrounding components and NFPA 70 approved. Access panels to the operator unit and return sprockets are required for adjustment and maintenance purposes, as provided by others. Electric operator shall consist of (select):
  1. Standard Speed Reducer Drive: consisting of a 50 to 1 ratio worm gear, adjustable clutch, and 1 H.P. (.746 kw) electric motor. The speed reducer drive system shall be capable of moving a wall system up to 600 ft.2 (56 m2).
- D.



### MODEL 2050 — Continuously-Hinged Electric Panels

#### SECTION 10 22 26 OPERABLE PARTITIONS SECTION 10 22 39 FOLDING PANEL PARTITIONS



#### 2.04 STACK ARRANGEMENTS

- A. Stack Type: Panel storage configuration shall be Center Stack, consisting of panels stacked on centerline to the wall's installed position.
- B. Stack Quantity: Panels shall be stored at (select):
  1. One End: on one end of the wall run.
  2. Both Ends: on both ends of the wall run.

#### 2.05 FINISHES

- A. Finish Material Type: Panel finish material shall be Class rated in accordance with ASTM E 84, consisting of (select):
  1. Vinyl: consisting of Type II, reinforced vinyl weighing 21 oz. / lin. yd. (651 g / lin. m). Vinyl shall meet or exceed CCC-W-408A and CFFA-W-101-D quality standards.
  2. Fabric: consisting of fade and tear resistant fabric that resists water-based stains weighing 13 oz. / lin. yd. (403 g / lin. m).
  3. Carpet: consisting of acoustically absorbent, non-woven needle punch fibers fused to prevent fraying and unraveling of material weighing 28.5 oz. / lin. yd. (884 g / lin. m). Basics Carpet shall achieve a minimum NRC (Noise Reduction Coefficient) rating of .20 (applied over gypsum substrate) in accordance with ASTM C423.
  4. Upgrade Carpet: consisting of acoustically absorbent, non-woven needle punch fibers fused to prevent fraying and unraveling of material weighing 23 oz. / lin. yd. (713 g / lin. m). Upgrade Carpet shall achieve a minimum NRC (Noise Reduction Coefficient) rating of .25 (applied over gypsum substrate) in accordance with ASTM C423.
  5. Digitally Printed Steel Skins: Seven-ply construction comprised of melted, rolled, coated, or printed layers. (52 and 50 STC steel skin panel construction only)
  6. Optional Unfinished: consisting of panels with exposed steel skins for field-applied wall covering or painting.
- B. Finish Material Supplier: Finish material shall be (select):
  1. Factory Supplied: from manufacturer's standard selection of finish materials, as specified.
  2. Customer Supplied: from customer's selection of finish material, by others, and as approved by KWIK-WALL Company.
- C. Finish Material Application: Finish material shall be (select):
  1. Factory Applied: by operable wall manufacturer. Customer-supplied finish material samples must be submitted to manufacturer for testing and approval prior to acceptance and application.
  2. Optional Field Applied: by others.

#### 2.06 PERIMETER TRIM AND SEALS

- A. A. Vertical Trim and Seals: Panels shall have vertical astragals containing flexible vinyl seals and incorporate reversible tongue-and-groove-type configurations for positive interlocking with adjacent panels. Vertical astragal type shall be (select):
  1. Trimless Astragal: consisting of an aluminum extrusion with tongue-and-groove-type vertical astragals. Vertical trim shall not be permitted on the panel faces, resulting in a minimal groove appearance between adjacent panels.
  2. Cap-type Astragal: consisting of an aluminum extrusion with tongue-and-groove-type vertical astragals for encapsulating and protecting the finish material and substrate along the vertical edge of the panel.
- B. Horizontal Top Trim and Seals: Top seals shall consist of flexible vinyl sweep seals installed on both sides of the panel. The seals shall consist of a compressed bulb between two (2) fingers of vinyl. Top seal type shall be fixed, consisting of continuous-contact flexible vinyl, sealing against the bottom flange of the overhead track.
- D. Horizontal Bottom Trim and Seals: Bottom seals shall consist of multiple fingers of flexible vinyl for positive contact and sealing with various floor surfaces. Bottom seal type shall be (select):
  1. Standard Adjustable Bottom Seals: consisting of field-adjustable, continuous-contact vinyl sweep seals with 2" [50.8] nominal height with 3/4" [19] of nominal adjustment.
- D. Horizontal and Vertical Panel Trim: All exposed panel trim and hinges shall be of one (1) similar color as selected from manufacturer's available colors.

#### 2.07 CLOSURE SYSTEMS

- A. Initial Closure System: The lead panel (the first panel exiting the stack) shall form a seal vertically against a rigid wall surface. The initial closure shall be accomplished by an Adjustable-Compensating Closure containing two (2) continuous-contact, flexible vinyl bulb seals installed along the vertical edge of the lead panel, for positive compression against a rigid wall surface. The initial closure panel shall contain a flush pull handle on each side.
- B. Final Closure System: The final closure panel (the last panel exiting the stack) shall form a seal vertically against a rigid wall surface. Final closure shall be accomplished by a Half Panel that requires attachment to the permanent wall. The first panel adjacent to the half panel shall contain a flush pull handle. The type of final closure panel shall be:



### MODEL 2050 — Continuously-Hinged Electric Panels

#### SECTION 10 22 26 OPERABLE PARTITIONS SECTION 10 22 39 FOLDING PANEL PARTITIONS



1. Manual Half-Panel Pivot Closure: consisting of a half-panel requiring manual activation when extending or retracting the operable wall. A half-panel interlock limit switch shall prevent the operable wall from being retracted until the half-panel and adjacent panel are partially folded.  
(Note: Minimum of five (5) panels required for Manual Half Panel Pivot Closure system.)

#### 2.08 ACOUSTICAL PERFORMANCE

- A. Certification: The operable wall shall have been tested in an independent acoustical testing laboratory in accordance with ASTM E 90 and ASTM E 413 test procedures.
- B. STC Rating: The operable wall acoustical performance rating shall be based on (select):
  1. Steel Skins: with a certified sound transmission class ratings of 52 STC or 50 STC.  
(Note: Not available with optional Wood Veneer or High-Pressure Laminate.)
  2. Acoustical Substrate: with certified sound transmission class ratings of 42 STC, 45 STC, 49 STC or 50 STC.

#### 2.09 PANEL ACCESSORIES

- A. Accessories including Single Pass Doors, Keyed Cylinder Locks, Concealed Door Closures, Room Viewers, Exit Signs, Dry Marker Writing Surfaces, Recessed Eraser Trays, Vision Lites, Tack Surfaces, and Pocket Doors shall be compatible with other accessories and options, furnished and installed by the operable wall manufacturer as noted on submitted shop drawings.

#### 2.10 SAFETY DEVICES

- A. Optional safety devices by Guardian Personnel Protection System™. The following safety devices shall shut the operable wall off immediately and prevent any movement until the system is reset at the control box (select):
  1. Floor Pressure Mats: consisting of molded vinyl mats (1/8" [3.18] thick) located in the pocket area and shall shut the operable wall system off immediately if a person or object is placed on mat. Floor mats shall only require 1 lb./ft.2 (4.88 kg/m2) of pressure to activate.  
(Note: Mat sizes may require additional width to pocket area.)

#### 2.11 TRACK SYSTEM

- A. Type H.D. Continuously Hinged / Electric Steel Track: The Continuously Hinged / Electric Steel track running surface shall be made of cold-rolled, high-carbon steel tread surfaces to facilitate ease of panel movement and operation. Track system shall require a panel guide to straighten out the wall system.

- B. The steel tread surface shall be contained within a continuous structural track housing extruded from aluminum, which prohibits deterioration caused by rust or corrosion. The track housing shall have a durable anodized clear satin finish, which resists color fading and flaking. The track housing shall utilize grooves and interlocking steel pins for positive alignment of adjacent track sections and shall be reinforced overhead by a heavy-duty steel bracket made of hot-rolled, 3/8" [10] thick plate steel. Aluminum track housing shall include an integral nut slot to accept hardened steel square nuts to facilitate attachment of each steel all-thread rod and splice brackets to the overhead structural support.

#### 2.12 CARRIER SYSTEM

- A. Type H.D. Continuously Hinged / Electric Steel Wheel Carrier: Continuously Hinged / Electric panel shall be top supported by one (1) carrier on every other panel, utilizing a 5/8" [16] diameter pendant bolt. Each top carrier shall consist of four (4) permanently lubricated, precision ball bearing polished steel wheels, as required for smooth and quiet operation.

#### 2.13 SUSPENSION SYSTEM

- A. Mounting System: The track shall be suspended by steel Drop Rods, consisting of adjustable rods of grade 2, 3/8" [10] diameter threaded steel all-rod provided with 3/8" [10] serrated steel nuts.

### PART 3 – EXECUTION

#### 3.01 INSPECTION

- A. Proper and complete preparation of the operable wall system opening shall be by others in accordance with the architectural drawings, manufacturer's shop drawings and ASTM E 557. Any deviation of the actual opening from these specifications shall be called to the attention of the architect prior to the installation of the operable wall.
- B. Deficiencies in the operable wall opening shall be corrected by others prior to installation of the operable wall.

#### 3.02 INSTALLATION

- A. The operable wall system shall be installed by manufacturer's authorized distributor.
- B. The operable wall shall be installed in accordance with manufacturer's written instructions, shop drawings and ASTM E 557 installation guidelines.

#### 3.03 ADJUSTING AND CLEANING

- A. The operable wall panels and track system shall be adjusted and cleaned in accordance with manufacturer's written instructions.



## MODEL 2050 — Continuously-Hinged Electric Panels

SECTION 10 22 26 OPERABLE PARTITIONS  
SECTION 10 22 39 FOLDING PANEL PARTITIONS

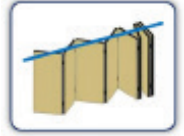

### 3.04 PROTECTION

- A. The operable wall panels shall be stored in the stacked (retracted) position prior to acceptance by the owner's representative.

### 3.05 DEMONSTRATION

- A. The operable wall manufacturer's authorized distributor shall demonstrate proper operation and explain proper and necessary maintenance requirements of the operable wall system to the owner's representative.

For additional information contact:

KWIK-WALL Company  
900 S. Cain St.  
Clinton, IL 61727  
Phone: 217-522-5553 or 800-280-5945  
(United States and Canada only)  
Fax: 217-522-1170 or 800-290-5945  
(United States and Canada only)

Website: [www.kwik-wall.com](http://www.kwik-wall.com)  
Email: [info@kwik-wall.com](mailto:info@kwik-wall.com)

Note:

Due to ongoing research and development, product specifications may vary.

5.2026

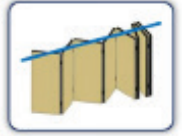
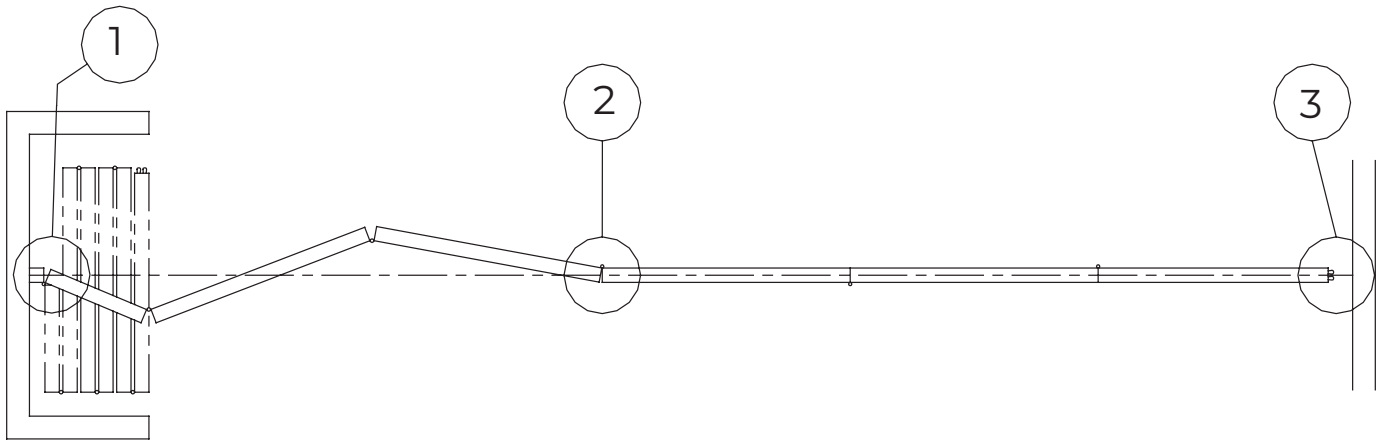
**MODEL 2050 — Continuously-Hinged Electric Panels**SECTION 10 22 26 OPERABLE PARTITIONS  
SECTION 10 22 39 FOLDING PANEL PARTITIONS**STACKING CONFIGURATIONS & JAMB CLOSURES****Half-Panel Closure**

For Model 2050, Continuously-Hinged Electric Panel operable walls, the final closure is accomplished by a half-panel which is hinged permanently and directly to a structural wall. Designed specifically for Continuously-Hinged walls, the half-panel and its two (2) immediately adjacent panels will incorporate standard adjustable bottom seals. The first (full size) panel adjacent to the half-panel will include a flush pull handle.



## MODEL 2050 — Continuously-Hinged Electric Panels

SECTION 10 22 26 OPERABLE PARTITIONS  
SECTION 10 22 39 FOLDING PANEL PARTITIONS



### HORIZONTAL DETAILS

#### with Trimless Vertical Astragal

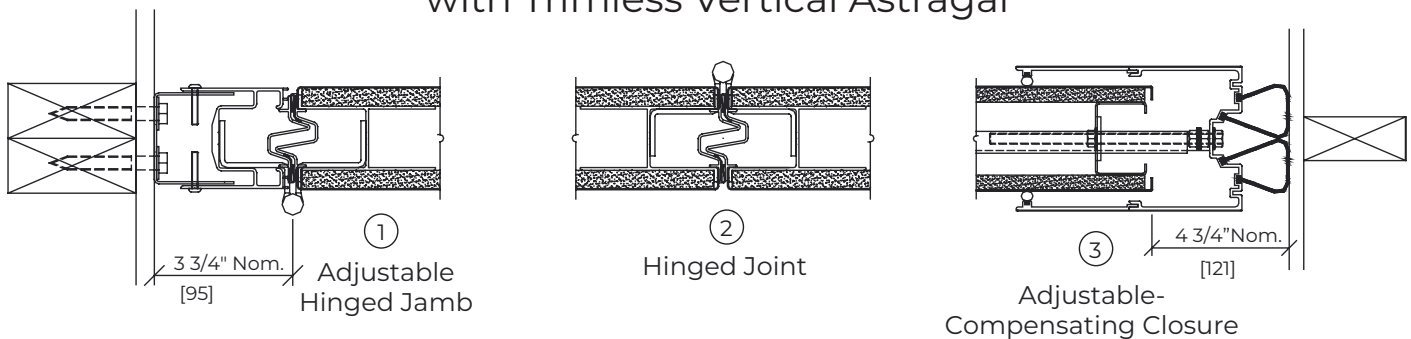

#### with Cap-Type Vertical Astragal

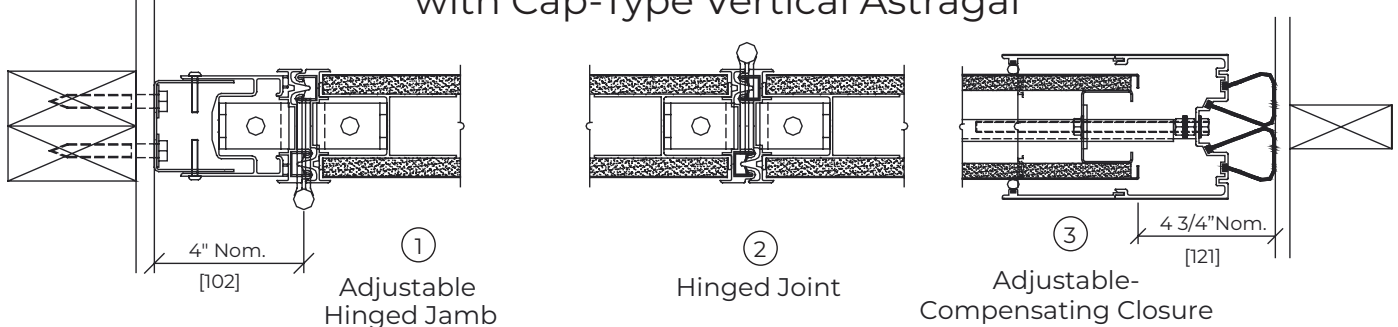



**MODEL 2050 — Continuously-Hinged Electric Panels**

SECTION 10 22 26 OPERABLE PARTITIONS  
SECTION 10 22 39 FOLDING PANEL PARTITIONS

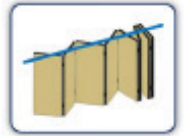

**VERTICAL DETAILS**

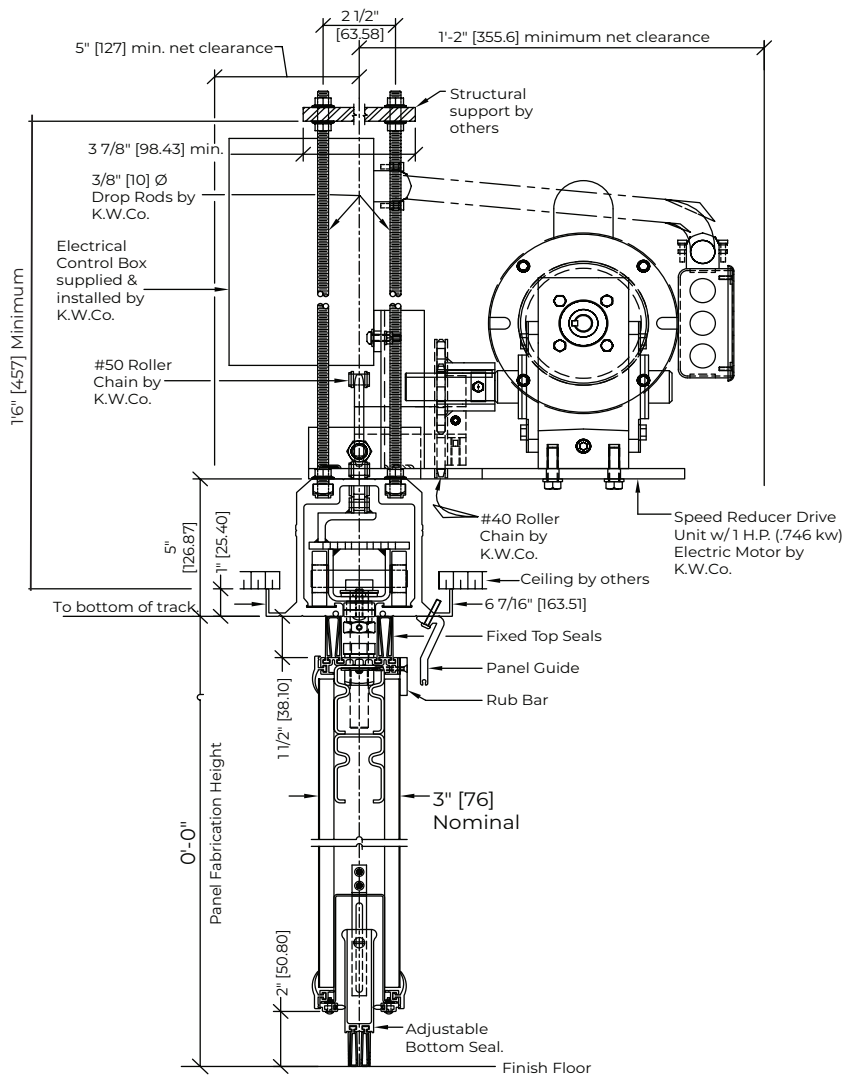

Model 2050 Vertical Detail  
with Speed Reducer Unit

**Notes:**

1. Maximum wall opening size shall not exceed 600ft. (56m<sup>2</sup>)
2. Adjustable Bottom Seals are standard on Final Closure Panel.



## MODEL 2050 — Continuously-Hinged Electric Panels

SECTION 10 22 26 OPERABLE PARTITIONS  
SECTION 10 22 39 FOLDING PANEL PARTITIONS



### ELECTRIC WALL LAYOUT

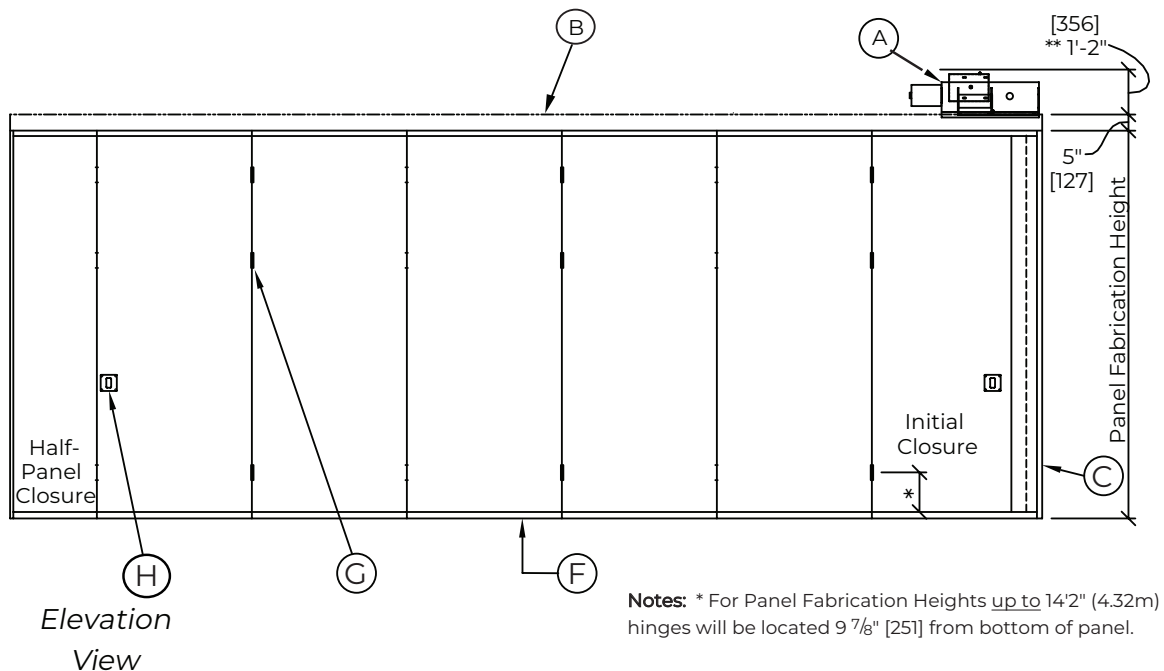
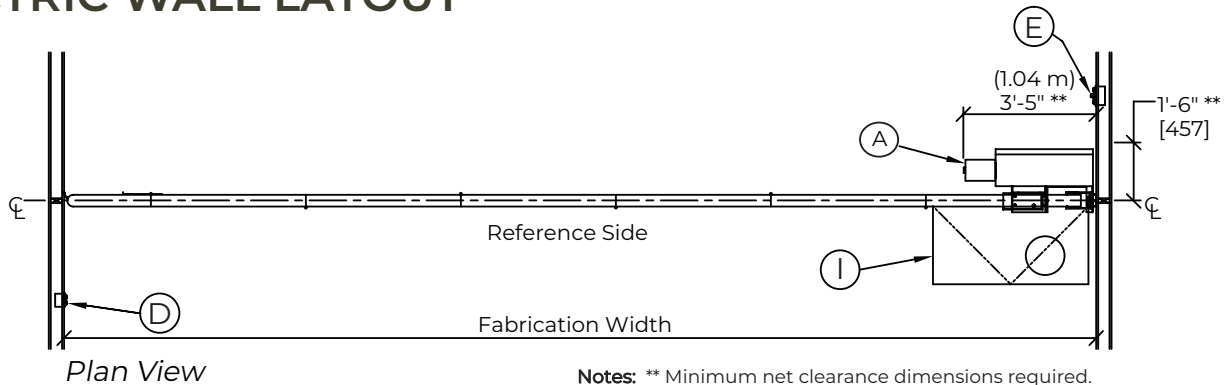

- |                                                                    |                                             |
|--------------------------------------------------------------------|---------------------------------------------|
| A. Speed Reducer Drive System                                      | F. Adjustable Fixed Bottom Seals            |
| B. 850 HD Continuously-Hinged Electric Track                       | G. Full Mortise Hinges                      |
| C. Adjustable Compensating Closure                                 | H. Flush Push/Pull Handle                   |
| D. Extend / Retract Constant Pressure Push Button Switch           | I. Flush Mount Access Panel (by others)     |
| E. Key Switch, Extend/Retract Constant Pressure Push Button Switch | 2'-0" 1.61 ml x 4'-0" [1.22 ml] recommended |



## MODEL 2050 — Continuously-Hinged Electric Panels

SECTION 10 22 26 OPERABLE PARTITIONS  
SECTION 10 22 39 FOLDING PANEL PARTITIONS



### TRACK OPTIONS

**Aluminum Track Systems**

Direct attach hanger rods to square nut raceway, **or** alternate attach with hanger brackets

Configuration Application

HP = Hinged Paired Panels  
CD = Individual Panels Curve & Diverter  
MD = Individual Panels Multi-Directional  
CH = Continuously-Hinged Electric Panels

2-7/8" [73]  
334 Lb. Limit  
4 3/4" [121]  
7/8" [22]  
**Type 425**  
MD

4 3/8" [108]  
850 Lb. Limit  
6 1/2" [165]  
7/8" [22]  
**Type 850**  
MD

2-1/2" Direct to Square Nut Raceway Spacing (typ. Except TIL Track)  
3 1/4" [83]  
850 Lb. Limit  
6 1/2" [165]  
7/8" [22]  
**Type 850**  
HP / CD

5-1/2" Hanger Rod Bracket Spacing (typ. All Track Systems)  
2-7/8" [73]  
425 Lb. Limit  
4 3/4" [121]  
7/8" [22]  
**Type 425**  
HP / CD

**Steel Track & Aluminum with Steel Tread Track Systems**

Direct attach hanger rods to square nut raceway, **or** alternate attach with hanger brackets

(typ. Except Type TIL Track)

Configuration Application

HP = Hinged Paired Panels  
CD = Individual Panels Curve & Diverter  
MD = Individual Panels Multi-Directional  
CH = Continuously-Hinged Electric Panels

5-1/2" Hanger Rods Only - No Square Nut Raceway Attachment  
4 1/8" [107]  
390 Lb. Limit  
5 1/4" [135]  
1" [25]  
**Type TIL**  
Steel Track w/ Aluminum Ceiling Trim  
HP

5" [127]  
1600 Lb. Limit  
6 7/16" [164]  
1" [25]  
**Type 850 HD**  
Alum. Track w/ Steel Tread Inserts and Steel-Tired Carriers  
HP / CD / CH

5-1/2" Hanger Bracket Rod Spacing (typ. All Track Systems)  
2-1/2" Rods Direct Attach to Square Nut Raceway  
2-7/8" [73]  
600 Lb. Limit  
4 3/4" [121]  
7/8" [22]  
**Type 425 SR**  
Alum. Track w/ Steel Tread Inserts and Steel-Tired Carriers  
HP / CD

- STC OPTIONS
- PANEL CONSTRUCTION
- PANEL WEIGHTS
- FRAME THICKNESS
- OPENING SIZE LIMITS

### Model 2050 – Continuously-Hinged Electric Panels



STC Rating	[S] Steel Skin or [A] Acoustic Substrate	Panel Weight lbs./ft <sup>2</sup>	Panel Thickness	Maximum Opening Height	Maximum Opening Width
52	S	9.2 [44.9 kg/m <sup>2</sup> ]	3"	16'-2" [4.93m]	Unlimited
50	S	8.6 [41.9 kg/m <sup>2</sup> ]	3"	16'-2" [4.93m]	Unlimited
42	A	6.5 [36.6 kg/m <sup>2</sup> ]	3"	14'-2" [4.32m]	Unlimited
45	A	7.5 [36.6 kg/m <sup>2</sup> ]	3"	14'-2" [4.32m]	Unlimited
49	A	9.0 [43.9 kg/m <sup>2</sup> ]	3"	14'-2" [4.32m]	Unlimited
50	A	9.0 [43.9 kg/m <sup>2</sup> ]	3"	14'-2" [4.32m]	Unlimited

**Note:** Panel weights are for standard intermediate panel function. Weights may vary due to substrate, panel finish and panel functionality. Add 105 lbs. [47 kg] for ea. pass door panel. Add 6 lbs. [3 kg] per lineal ft. height for each expander panel. Add 3.5 lbs. to 8 lbs. [1.6 kg – 3.6 kg] per lineal foot for track weight.

Finishes requiring acoustic substrate construction: High Pressure Laminate & Wood Veneer.

Please refer to: ASTM E 557 "Standard Guide for the Installation of Operable Partitions", for specifics on structural support deflection; floor flatness; and sound transmission flanking path surrounding construction.



**MODEL 2050** — Continuously-Hinged Electric Panels

SECTION 10 22 26 OPERABLE PARTITIONS  
 SECTION 10 22 39 FOLDING PANEL PARTITIONS

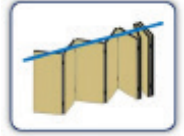

**ELEVATION DETAIL**

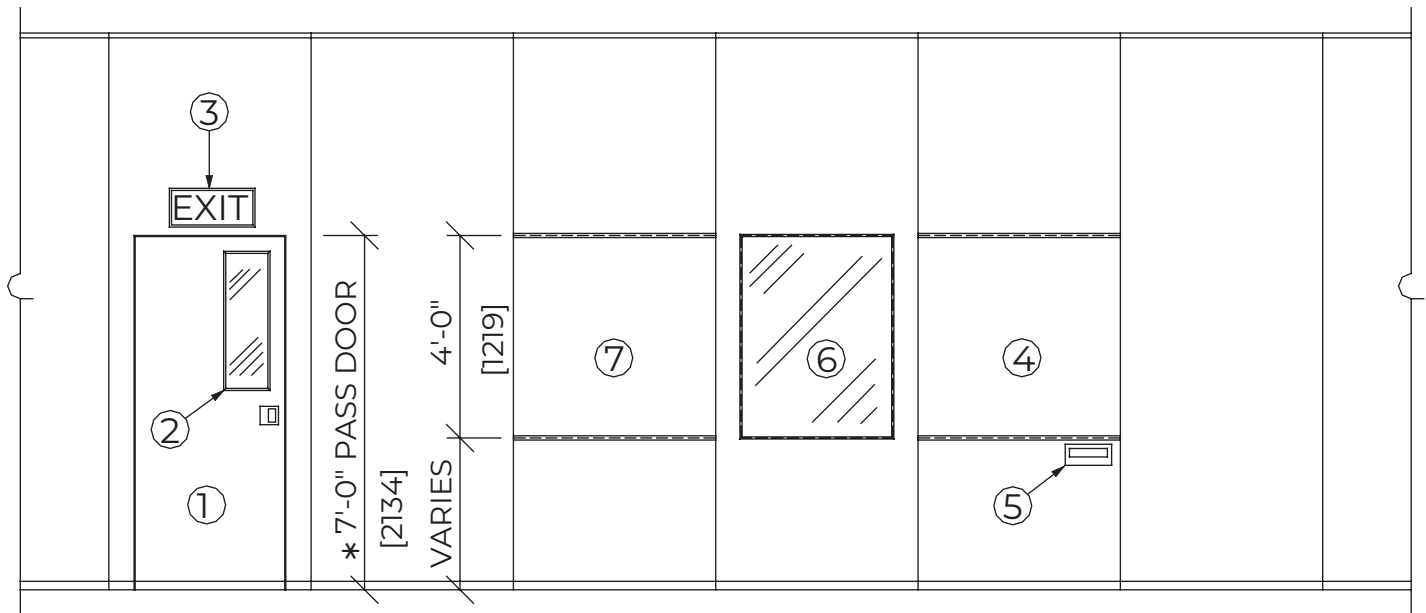

**ACCESSORIES**

- |                                                                                                                                                                                     |                                                                                                                                                                      |
|-------------------------------------------------------------------------------------------------------------------------------------------------------------------------------------|----------------------------------------------------------------------------------------------------------------------------------------------------------------------|
| <ul style="list-style-type: none"> <li>1. Pass Door (Single shown, double available)</li> <li>2. Pass Door Vision Lite</li> <li>3. Exit Sign</li> <li>4. Writing Surface</li> </ul> | <ul style="list-style-type: none"> <li>5. Recessed Eraser Tray</li> <li>6. Panel Vision Lite</li> <li>7. Tack Surface</li> <li>8. Pocket Door (Not shown)</li> </ul> |
|-------------------------------------------------------------------------------------------------------------------------------------------------------------------------------------|----------------------------------------------------------------------------------------------------------------------------------------------------------------------|

**Notes:**

- 1. \* 7'-8" (2.34m) minimum panel fabrication height required.
- 2. For complete specifications and details of KWIK-WALL Accessories, please visit our website at [www.kwik-wall.com](http://www.kwik-wall.com).