

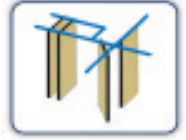

## MODEL 3020 — Individual Multi-Directional Panels

SECTION 10 22 26 [10650] Operable Partitions

SECTION 10 22 39 Folding Panel Partitions



### Overview

#### Panel Type

- Individual Panels Curve & Diverter
- Individual Panels – Multi Directional
- Hinged-Paired
- Continuously-Hinged

#### Partition Operation

- Manual
- Electric

#### Stacking Configurations

- Centerline
- Offset
- Remote
- Bi-Parting

#### STC Options

A=Acoustic Substrate S=Steel Skin

- 56S
- 52S
- 50S
- 46S
- 43A
- 46A
- 48A
- 50A

#### Panel Finishes

- Vinyl
  - Fabric
  - Carpet
  - Digitally Printed Steel Skin
  - High Pressure Laminate
  - Wood Veneer
  - Customer Supplied\*
- \* Material Subject to Kwik-Wall approval

#### Vertical Panel Joints

- Trimless
- Capped Trim

#### Top Seals

- Fixed
- Operable

#### Bottom Seals

- Fixed
- Adjustable Fixed
- Operable
- Automatic
- Extended

#### Available Options

Storage pocket doors; ADA Pass Doors – (single, double with panic hardware, concealed door closures & exit signs); invisible hinges; dry marker surfaces; insulated glass unit inserts; tack surfaces.

**KWIK-WALL's Model 3020** – featuring individual, multi-directional panels capable of making 90° turns at X, L, or T track intersections, allowing multiple layout and panel storage options. With STC options from 43-56, 3000 Series Operable Walls offer industry-leading premium sound control.

Model **3020** construction features panels that are 4" [101.6] thick, manufactured of a durable roll-formed steel frame, and standard steel skins for maximum durability and sound control. Optional acoustical glass inserts are available to add daylighting.



90° X, L, T intersections

#### 3000 Series Panel Weights

STC	lbs/sq ft	kg/m2
56S	12.9 lbs/sq ft	[63 kg/m2]
52S	9.5 lbs/sq ft	[46 kg/m2]
50S	9.5 lbs/sq ft	[46 kg/m2]
46S	8.5 lbs/sq ft	[41 kg/m2]
43A	5.9 lbs/sq ft	[29 kg/m2]
46A	6.6 lbs/sq ft	[32 kg/m2]
48A	7.5 lbs/sq ft	[37 kg/m2]
50A	9.0 lbs/sq ft	[44 kg/m2]



3020

More Information



## MODEL 3020 — Individual Multi-Directional Panels

### SECTION 10 22 26 [10650] Operable Partitions

### SECTION 10 22 39 Folding Panel Partitions

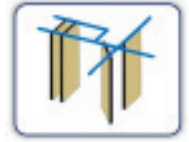

#### PART 1 – GENERAL

##### 1.01 WORK INCLUDED

- A. Operable Wall System shall be furnished, installed, and serviced by wall manufacturer's authorized distributor, in compliance with the architectural drawings and specifications contained herein.

##### 1.02 RELATED WORK

- A. Structural Support: Structural support system required for suspending the operable wall shall be designed, installed and pre-punched by others, in accordance with ASTM E 557 and manufacturer's shop drawings.
- B. Insulation: Sound insulation and baffles for the plenum area above the track system, under the permanent floor, inside air ducts passing over or around the operable wall, and in permanent walls adjoining the operable wall system shall be by others, in accordance with ASTM E 557.
- C. Opening Preparation: Proper and complete preparation of the operable wall system opening shall be by others in accordance with ASTM E 557 and shall include floor leveling; plumbness of adjoining permanent walls; substrate and/or ceiling tile enclosures for the track system; and the painting and finishing of trim and other materials adjoining the head and jamb areas of the operable wall. Any permanent wall(s) receiving an adjustable or fixed wall jamb will require internal structural blocking to secure the jamb to the permanent wall. Refer to a copy of the shop drawings for additional details.

##### 1.03 SYSTEM DESCRIPTION

- A. The operable wall system shall consist of Individual Panels top supported by two (2) multi-directional carriers capable of negotiating 90o "X", "L" and "T" intersections.
- B. The operable wall system shall consist of acoustically rated panels tested in accordance with ASTM E 90 and ASTM E 413 test procedures and shall have achieved a STC rating as specified herein (see "Acoustical Performance" article listed under Part 2 – Products).

##### 1.04 QUALITY ASSURANCE

- A. The operable wall shall have been tested in an independent acoustical testing laboratory in accordance with ASTM E 90 and ASTM E 413 test procedures.
- B. The operable wall panel construction and finish materials shall consist of Class A-rated materials in accordance with ASTM E 84.
- C. The operable wall shall be installed by the manufacturer's authorized distributor in accordance with ASTM E 557.

##### 1.05 REFERENCES

- A. ASTM E 90: Laboratory Measurement of Airborne-Sound Transmission Loss of Building Partitions.
- B. ASTM E 413: Determination of Sound Transmission Class (STC).
- C. ASTM E 557: Architectural Application and Installation of Operable Partitions.
- D. ASTM E 84: Surface Burning Characteristics of Building Materials.
- E. ASTM A 653: Specification for General Requirements for Steel Sheet, Alloy-Coated (Galvannealed) by the Hot Dip Process.
- F. ASTM C 423: Standard Test Method for Sound Absorption and Sound Absorption Coefficients by the Reverberation Room Method.
- G. CCC-W-408A: Federal Specification which applies to Vinyl Coated Wall Coverings.
- H. CFFA-W-101-D: Chemical Fabrics and Film Association Quality Standard for Vinyl Coated Fabric Wall Coverings.
- I. ATTM E 2190: Certification and testing for Insulated Glass inserts.

##### 1.06 SUBMITTALS

- A. Manufacturer shall provide written technical information and related detail drawings, which demonstrate that the products comply with contract documents for each type of operable partition specified.
- B. Manufacturer shall provide detailed engineering drawings featuring track plan, panel elevation, horizontal and vertical details and beam punching template as required.
- C. Manufacturer shall provide written test report of the independent acoustical testing laboratory certifying the attainment of the specified STC rating, upon request.
- D. Manufacturer shall provide written instructions specifying the proper operation and maintenance of the operable wall system.
- E. Manufacturer shall provide a color selector demonstrating the manufacturer's selections of the specified finish material. Samples shall consist of actual swatches of the specified finish material.

##### 1.07 DELIVERY, STORAGE AND HANDLING

- A. Panels shall be individually wrapped in a protective plastic covering to keep panels clean during delivery, storage and handling.
- B. Panels shall be stored on edge and above the floor on cushioned blocking in a dry and ventilated area, protected from humidity and temperature extremes.



## MODEL 3020 — Individual Multi-Directional Panels

### SECTION 10 22 26 [10650] Operable Partitions

### SECTION 10 22 39 Folding Panel Partitions



#### 1.08 SEQUENCING / SCHEDULING

- A. Beam Punching: Manufacturer shall provide beam punching template drawing detailing the anchor locations for the suspended track system (as required for Drop Rod Mounting), as required for the fabrication and installation of structural overhead support by others.
- B. Track Installation: Scheduling of operable wall track installation shall occur after structural overhead support has been properly and completely fabricated and installed by others.
- C. Panel Installation: Operable wall panel installation shall occur after fixed wall substrate construction is properly and completely installed by others, as required to protect panels from ongoing adjacent construction.

#### 1.09 WARRANTY

- A. Manufacturer shall warrant each operable wall panel and its component parts to be free from defects in material and workmanship for a period of ten (10) years from the date of delivery to the original purchaser, when installed by an authorized KWIK-WALL distributor. KWIK-WALL also warrants the fixed top seals, track, carriers, and its component parts to be free from defects in material and workmanship for a period of ten (10) years. (Glass is specifically excluded from the warranty.) (Contact your local KWIK-WALL Distributor or KWIK-WALL Company for complete warranty information.)

## PART 2 – PRODUCTS

### 2.01 ACCEPTABLE MANUFACTURER

- A. Operable walls shall be Series 3000, Model 3020/3020GL Individual Panels / Multi-Directional as manufactured by KWIK-WALL Company.

### 2.02 PANEL CONSTRUCTION

- A. Panel Dimensions: Standard panel dimension shall be a nominal 4" [101.6] thick.
- B. Panel Frame: Steel frame shall be 16-gauge galvanized steel, horizontal top cross member shall be minimum 12-gauge galvanized steel which meets or exceeds ASTM A 653 requirements. Frame shall be all-welded construction with steel corner supports and cross-bracing reinforcement. Panel frame shall be Class A rated, fire retardant, non-combustible and non-corrosive in accordance with ASTM E 84.
- C. Panel Skins: Panel skins shall be Class A rated (except Wood Veneer and High-Pressure Laminate) in accordance with ASTM E 84. Panel skin material shall consist of (select):
  1. Steel Skins: consisting of minimum 22-gauge tension-lev- eled galvanized steel, pressure laminated to a structural acoustical backer and mechanically joined to the steel frame to form a rigid, unitized, and structural panel.

2. Acoustical Substrate: consisting of structural acoustical substrate pressure laminated to both sides of the steel frame to form a rigid, unitized and structural panel.
  3. Wood Veneer: consisting of particle board core covered with wood veneer and pressure laminated to both sides of the steel frame to form a rigid, unitized and structural panel.
  4. High-Pressure Laminate: consisting of gypsum board core covered with general purpose plastic laminate and Phenolic backer sheet, which is pressure laminated to both sides of the steel frame to form a rigid, unitized and structural panel.
- D. Optional Glass: Opening cut out in panel shall be glazed with insulated glass that is manufactured in accordance with ASTM E 2190. Glass type shall be an acoustical insulated glass unit. Glass shall be retained in opening cut out using an aluminum extrusion.
  - E. Panel Weight: Maximum panel weight shall be 5.9 – 12.9 lb./ ft.2 (29 – 63 kg/m<sup>2</sup>) depending on STC rating, size and options selected.

### 2.03 OPERATION

- A. Operation shall be Individual Panels with a Multi-Directional track system that allows the panels to negotiate 90o "X", "L" and "T" intersections as required for movement of panels from storage location(s) to various installed positions. Panels shall be top supported by two (2) carriers featuring dual horizontal precision bearings with high strength polymer tires riding on a structural aluminum track.

### 2.04 STACK ARRANGEMENTS

- A. Stack Type: Panel storage configuration shall be (select):
  1. Perpendicular Stack: consisting of panels stacked perpendicular to the wall's installed position.
  2. Parallel Stack: consisting of panels stacked parallel to the wall's installed position.
  3. Remote Stack: consisting of panels located remotely from the wall's installed position, as shown on submitted shop drawings.
- B. Stack Quantity: Panels shall be stored in separate stack areas as required for panel storage.

### 2.05 FINISHES

- A. Finish Material Type: Panel finish material shall be Class A-rated (except wood veneer and high-pressure laminate) in accordance with ASTM E 84, consisting of (select):
  1. Vinyl: consisting of Type II, reinforced vinyl weighing 21 oz./lin. yd. (651 g/lin. m). Vinyl shall meet or exceed CCC-W-408A and CFFA-W-101-D quality standards.



## MODEL 3020 — Individual Multi-Directional Panels

### SECTION 10 22 26 [10650] Operable Partitions

### SECTION 10 22 39 Folding Panel Partitions



2. Fabric: consisting of fade and tear resistant fabric that resists water-based stains, weighing 13 oz./lin. yd. (403 g/lin. m).
  3. Standard Carpet: consisting of acoustically absorbent, non-woven needle punch fibers fused to prevent fraying and unraveling of material weighing 28.5 oz./lin. yd. (884 g/lin. m). Basics Carpet shall achieve a minimum NRC (Noise Reduction Coefficient) rating of .20 (applied over gypsum substrate) in accordance with ASTM C423.
  4. Upgrade Carpet: consisting of acoustically absorbent, non-woven needle punch fibers fused to prevent fraying and unraveling of material weighing 23 oz./lin. yd. (713 g/lin. m). Upgrade Carpet shall achieve a minimum NRC (Noise Reduction Coefficient) rating of .20 (applied over gypsum substrate) in accordance with ASTM C423.
  5. Wood Veneer: consisting of unfinished flat cut wood veneer laminated to 1/2" [12.7] thick particle board core. Veneer shall be book / running matched within a panel, and edge banded if Trimless astragals are specified. (Notes: Optional Class "A" rated particle board is available. Acoustical substrate STC ratings apply for Wood Veneer panel construction.)
  6. High-Pressure Laminate: consisting of gypsum board core covered with general-purpose plastic laminate and Phenolic backer sheet, which is pressure laminated to both sides of the steel frame to form a rigid, unitized, and structural panel.  
(Note: Acoustical substrate STC ratings apply for High Pressure Laminate panel construction.)
  7. Digitally Printed Steel Skins: Seven-ply construction comprised of melted, rolled, coated, or printed layers.
  8. Optional Unfinished: consisting of panels with exposed acoustical substrate or steel skins for field applied wall-covering or painting.
- B. Finish Material Supplier: Finish material shall be (select):
1. Standard Factory Supplied: from manufacturer's standard selection of finish materials, as specified.
  2. Optional Customer Supplied: from customer's selection of finish material, by others, and as approved by KWIK-WALL Company.
- C. Finish Material Application: Finish material shall be (select):
1. Factory Applied: by operable wall manufacturer. Customer supplied finish material samples must be submitted to manufacturer for testing and approval prior to acceptance and application.
  2. Field Applied: by others.

#### 2.06 PERIMETER TRIM AND SEALS

- A. Vertical Trim and Seals: Panels shall have vertical astragals containing flexible vinyl seals and incorporate reversible tongue-and-groove-type configurations for positive interlocking with adjacent panels. Vertical astragal type shall be (select):
1. Trimless Astragal: consisting of an aluminum extrusion with tongue-and-groove-type vertical astragals. Vertical trim shall not be permitted on the panel faces, resulting in a minimal groove appearance between adjacent panels.
  2. Cap-type Astragal: consisting of an aluminum extrusion with tongue-and-groove-type vertical astragals for encapsulating and protecting the finish material and substrate along the vertical edge of the panel.
- B. Horizontal Top Trim and Seals: Top seals shall consist of flexible vinyl sweep seals installed on both sides of the panel. The seals shall consist of a compressed bulb between two (2) fingers of vinyl. Top seal type shall be (select):
1. Fixed Top Seals: consisting of continuous-contact flexible vinyl sealing against the bottom flange of the overhead track.
  2. Operable Top Seals: consisting of an edge-activated seal using a removable wrench as supplied by manufacturer. Top seals shall provide a maximum 1/2" [13] of travel. (Note: Available only with Standard Operable Bottom Seals.)
- C. Horizontal Bottom Trim and Seals: Bottom seals shall consist of multiple fingers of flexible vinyl for positive contact and sealing with various floor surfaces. Bottom seal type shall be (select):
1. Operable Bottom Seals: consisting of an edge-activated seal using a removable wrench as supplied by manufacturer. Bottom seals shall provide 2" [50.8] of nominal travel.
  2. Adjustable Bottom Seals: consisting of field adjustable, continuous-contact vinyl sweep with 2" [50.8] nominal height with 3/4" [19] of adjustment.
  3. Automatic Bottom Seals: consisting of self-activated seals providing 2" [50.8] of nominal travel.
- D. Horizontal and Vertical Panel Trim: All exposed panel trim and hinges shall be of one (1) similar color as selected from manufacturer's available trim colors.

#### 2.07 CLOSURE SYSTEMS

- A. Initial Closure System: The lead panel (the first panel exiting the stack) shall form a seal vertically against a rigid wall surface, as accomplished by a (select):
1. Bulb Seal: consisting of continuous-contact, flexible vinyl bulb seals installed along the vertical edge of the lead panel for positive compression against a rigid wall surface.



## MODEL 3020 — Individual Multi-Directional Panels

### SECTION 10 22 26 [10650] Operable Partitions

### SECTION 10 22 39 Folding Panel Partitions

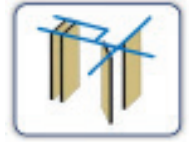

2. Fixed Starter Jamb: consisting of an aluminum extrusion, which is permanently mounted to a structural wall surface. The Fixed Starter Jamb shall incorporate a tongue-and-groove-type vertical astragal for positive interlocking with the lead panel.
  3. Adjustable Starter Jamb: consisting of an aluminum extrusion which is permanently mounted to a structural wall surface and is field-adjustable to compensate for out-of-plumb conditions of the fixed wall. The Adjustable Starter Jamb shall incorporate a tongue-and-groove-type vertical astragal for positive interlocking with the lead panel.
- B. Final Closure System: The final closure panel (the last panel exiting the stack) shall form a seal vertically against a rigid wall surface. The type of final closure panel shall be (select):
1. Expander Panel Closure: consisting of an expander mechanism with a nominal 5" [127] of travel, activated from the face of the panel using a removable wrench as supplied by manufacturer. The Expander Panel shall be equipped with an adjustable bottom seal or operable bottom seal, and a flush pull handle.
  2. Hinged Panel(s) Closure: consisting of a panel hinged permanently and directly to a structural wall surface. The Hinged Panel(s) shall be equipped with an adjustable bottom seal, a lap-type extrusion for sealing against its adjacent panel (standard) or (optional) expander mechanism with a nominal 5" [127] of travel, and a flush pull handle on each side of the panel.
  3. Optional Pocket Door(s): (see "Series 3000 Pocket Door" technical data sheet for complete details and specifications).

#### 2.08 ACOUSTICAL PERFORMANCE

- A. Certification: The operable wall shall have been tested in an independent acoustical testing laboratory in accordance with ASTM E 90 and ASTM E 413 test procedures.
- B. STC Rating: The operable wall acoustical performance rating shall be based on (select):
1. *Steel Skins: 46 STC, 50 STC, 52 STC, 56 STC.*  
(Note: Not available with optional Wood Veneer or High-Pressure Laminate.)
  2. Acoustical Substrate: 43 STC, 46 STC, 48 STC or 50 STC.

#### 2.09 PANEL ACCESSORIES

- A. Accessories, including Pass Doors; Single or Double, Keyed Cylinder Locks, Concealed Door Closures, Room Viewers, Exit Signs, Dry Marker Writing Surfaces, Recessed Eraser Trays, Vision Lites, Tack Surfaces, and Pocket Doors, shall be compatible with other accessories and options, furnished and installed by the operable wall manufacturer as noted on submitted shop drawings.

#### 2.10 TRACK SYSTEMS

- A. Track Type: The operable wall track system shall be extruded from structural aluminum alloy, which prohibits deterioration caused by rust or corrosion. The aluminum track shall have a durable anodized clear satin finish, which resists color fading and flaking. The track shall utilize grooves and interlocking steel pins for positive alignment of adjacent track sections. The track joints shall be reinforced overhead by a heavy-duty steel bracket made of hot-rolled, 3/8" [10] thick plate steel. Aluminum track shall include an integral nut slot to accept a hardened steel square nut to facilitate attachment of each steel all-rod and splice brackets to the overhead structural support.
- B. Track Size: The track size shall be:
1. Type 425 Multi-Directional Aluminum Track: certified to be capable of supporting up to 525 lb. (238 kg) of total live load weight per panel.
  2. Type 850 Multi-Directional Aluminum Track: certified to be capable of supporting up to 850 lb. (386 kg) of total live load weight per panel.

#### 2.11 CARRIER SYSTEMS

- A. Carrier Type: Each Individual Panel shall be top supported by two (2) carriers utilizing a 5/8" [16] diameter pendant bolt. Each carrier shall consist of dual horizontal, permanently lubricated, precision-ground steel bearings with high-strength polymer tires as required for smooth and quiet operation. Multi-Directional carriers shall be capable of negotiating 90o "X", "L" and "T" intersections as required for moving panels from storage location(s) to various installed positions.
- B. Carrier Size: The carrier size shall be:
1. Type 425 Multi-Directional Carrier: certified to be capable of supporting up to 525 lb. (238 kg) of total live load weight per panel.
  2. Type 850 Multi-Directional Carrier: certified to be capable of supporting up to 850 lb. (386 kg) of total live load weight per panel.



## MODEL 3020 — Individual Multi-Directional Panels

SECTION 10 22 26 [10650] Operable Partitions

SECTION 10 22 39 Folding Panel Partitions

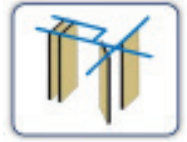

### 2.12 SUSPENSION SYSTEMS

- A. Mounting Systems: The track shall be supported by (select):
1. Drop Rod Mount: consisting of adjustable rods of grade 2, 3/8" [10] diameter threaded steel all-rod provided with 3/8" [10] serrated steel nuts.
  2. Drop Rod Bracket Mount: consisting of 3/8" [10] thick steel brackets mounted to top of track and supported with adjustable rods of grade 2, 3/8" [10] diameter threaded steel all-rod provided with 3/8" [10] serrated steel nuts.
  3. Direct Mount: consisting of 3/8" [10] x 3" [76] lag screws for attachment to an overhead structural (wood) support. (Direct mount track installations should not exceed 425 lb. (193 kg) of panel weight.)

For additional information, contact:  
KWIK-WALL Company  
900 S. Cain St.  
Clinton, IL 61727

Phone: 217-522-5553 or 800-280-5945  
(United States and Canada only)  
Fax: 217-522-1170 or 800-290-5945  
(United States and Canada only)

Website: [www.kwik-wall.com](http://www.kwik-wall.com)  
Email: [info@kwik-wall.com](mailto:info@kwik-wall.com)

#### Note:

Due to ongoing research and development, some variations may occur in product specifications.  
06.26

## PART 3 – EXECUTION

### 3.01 INSPECTION

- A. Proper and complete preparation of the operable wall system opening shall be by others in accordance with the architectural drawings, manufacturer's shop drawings, and ASTM E 557. Any deviation of the actual opening from these specifications shall be called to the attention of the architect prior to the installation of the operable wall.
- B. Deficiencies in the operable wall opening shall be corrected by others prior to installation of the operable wall.

### 3.02 INSTALLATION

- A. The operable wall system shall be installed by manufacturer's authorized distributor.
- B. The operable wall shall be installed in accordance with manufacturer's written instructions, shop drawings and ASTM E 557 installation guidelines.

### 3.03 ADJUSTING AND CLEANING

- A. The operable wall panels and track system shall be adjusted and cleaned in accordance with manufacturer's written instructions.

### 3.04 PROTECTION

- A. The operable wall panels shall be stored in the stacked (retracted) position prior to acceptance by the owner's representative.

### 3.05 DEMONSTRATION

- A. The operable wall manufacturer's authorized distributor shall demonstrate proper operation and explain proper and necessary maintenance requirements of the operable wall system to the owner's representative.



**MODEL 3020 — Individual Multi-Directional Panels**

SECTION 10 22 26 [10650] Operable Partitions

SECTION 10 22 39 Folding Panel Partitions

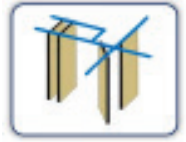

**STACKING CONFIGURATIONS**

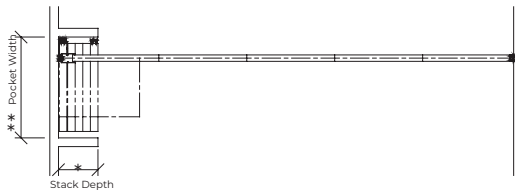

**Perpendicular Stack**

Perpendicular stacking allows individual panels to be located at one (1) or both ends and stored perpendicular to the wall's installed position..

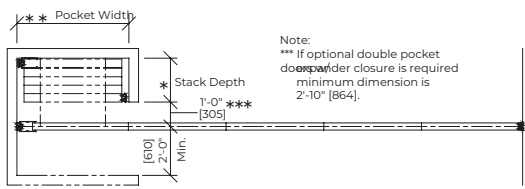

**Parallel Stack**

In contrast to perpendicular stacking, Individual Panel arrangements may also be stored parallel to the wall's installed position, at one (1) or both ends..

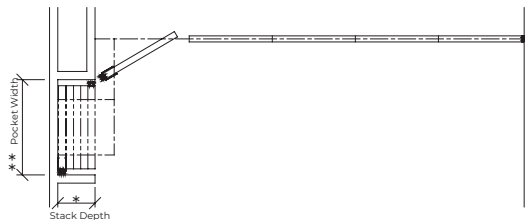

**Remote Stack**

For more complex wall system layouts, or when space or other room constraints dictate, Individual Panels may be located remotely from the wall's installed position.

**Stack Depth\***

The overall depth of the stack area, as required for panel storage, is dictated by the total number of panels in the wall system. Luminous Atlas Panels require an average stack depth of 4 3/8" [111] per panel. To determine the stack depth, calculate as follows:

**Number of Panels x 4 3/8" [111]**

\*Note: Additional stack depth is required for wall systems containing the following type of panels:

- Expander Panel Closure or Pass Door Panel: 3/4" [19]
- Hinged Panel(s) Closure: 4" [102]
- Pocket Door(s): 6" [152]

\*\*Note: For wall systems that include Pocket Doors, please reference KWIK-WALL's "3000 Series Pocket Door" technical data sheet for pocket layout dimensions and applications.

**Pocket Width\*\***

The width of the pocket is determined by the widest panel in the wall run. For specification purposes, assume the widest panel is 4'-0" (122cm) maximum. Wall systems that utilize Automatic type bottom seals will require extra pocket width to allow clearance for the actuator that protrudes from the bottom of the lead panel. Pocket width may be calculated as follows:

*If Adjustable or Operable Bottom Seals are specified:*

**Panel Width + 7" [178]**  
(allows 3 1/2" [89] for hand clearance on each side)

*If Automatic Bottom Seals are specified:*

**Panel Width + 10" [254]**  
(for actuator clearance on one side)

plus

**3 1/2" [89]**  
(for hand clearance on one side)



## MODEL 3020 — Individual Multi-Directional Panels

SECTION 10 22 26 [10650] Operable Partitions

SECTION 10 22 39 Folding Panel Partitions

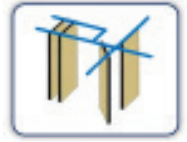

### STACKING CONFIGURATIONS FINAL CLOSURES

#### Expander Panel Closure

The final closure panel is equipped with an expander saddle located on the vertical edge of the panel that mechanically telescopes outward to create a positive contact seal with a rigid wall, pocket door or jamb. The expansion of the expander saddle is activated by inserting a wrench into an escutcheon plate located on the panel face. The expander panel is equipped with a flush pull handle and an adjustable bottom seal (standard) or (optional) operable bottom seal.

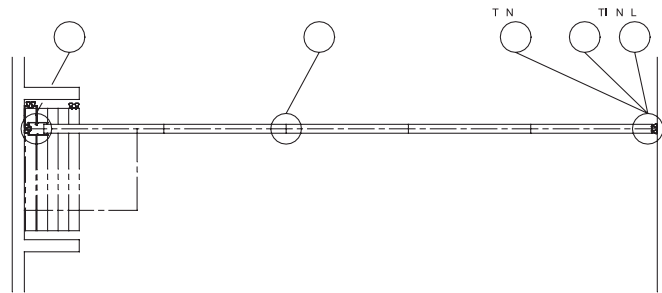

#### Hinged Panel(s) Closure

This final closure configuration is accomplished by a panel(s) which is hinged permanently and directly to a structural wall member. The hinged panel(s) features adjustable bottom seals and includes a flush pull handle on each side of the panel.

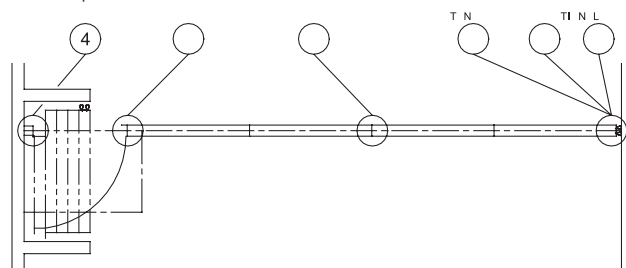

#### Double Pocket Doors with Expander Closure

The pocket door is equipped with an expander mechanism in the same way as the more common expander panel. Rather than being located on a wall panel, the expander saddle is integrated into a pocket door panel. The saddle expander will be fully retracted with a pair of bulb seals compressed against the last panel exiting the stack. The pocket doors are provided with fixed bottom seals as a factory standard and includes a footbolt and flush pull handle.

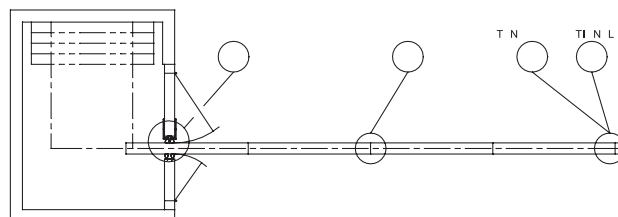



**MODEL 3020 — Individual Multi-Directional Panels**

SECTION 10 22 26 [10650] Operable Partitions

SECTION 10 22 39 Folding Panel Partitions

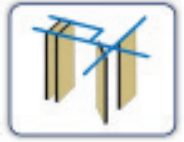

**HORIZONTAL TRIMLESS DETAILS**

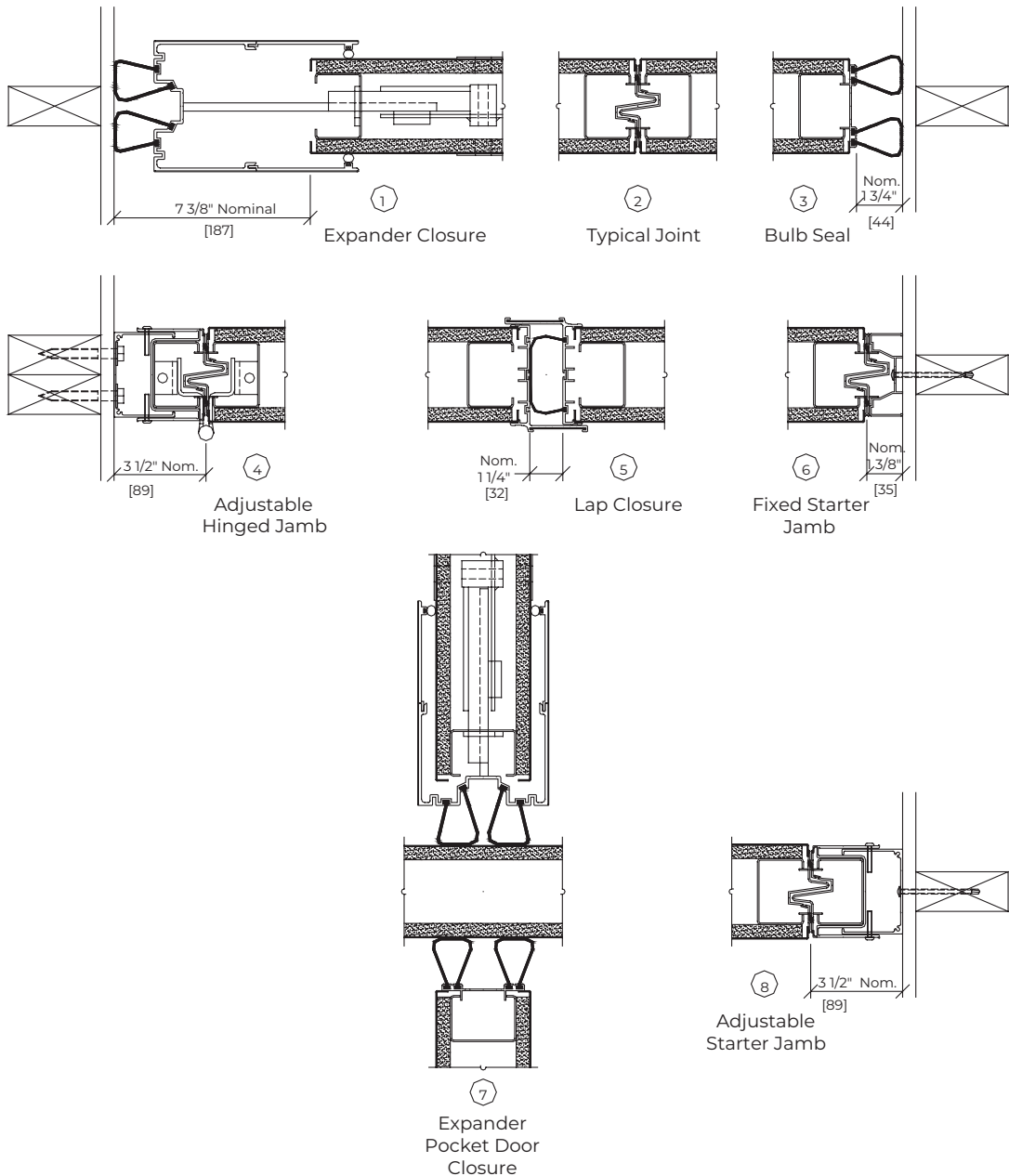



**MODEL 3020** — Individual Multi-Directional Panels

SECTION 10 22 26 [10650] Operable Partitions

SECTION 10 22 39 Folding Panel Partitions

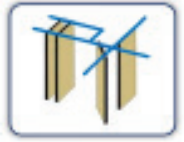

**HORIZONTAL CAP-TYPE DETAILS**

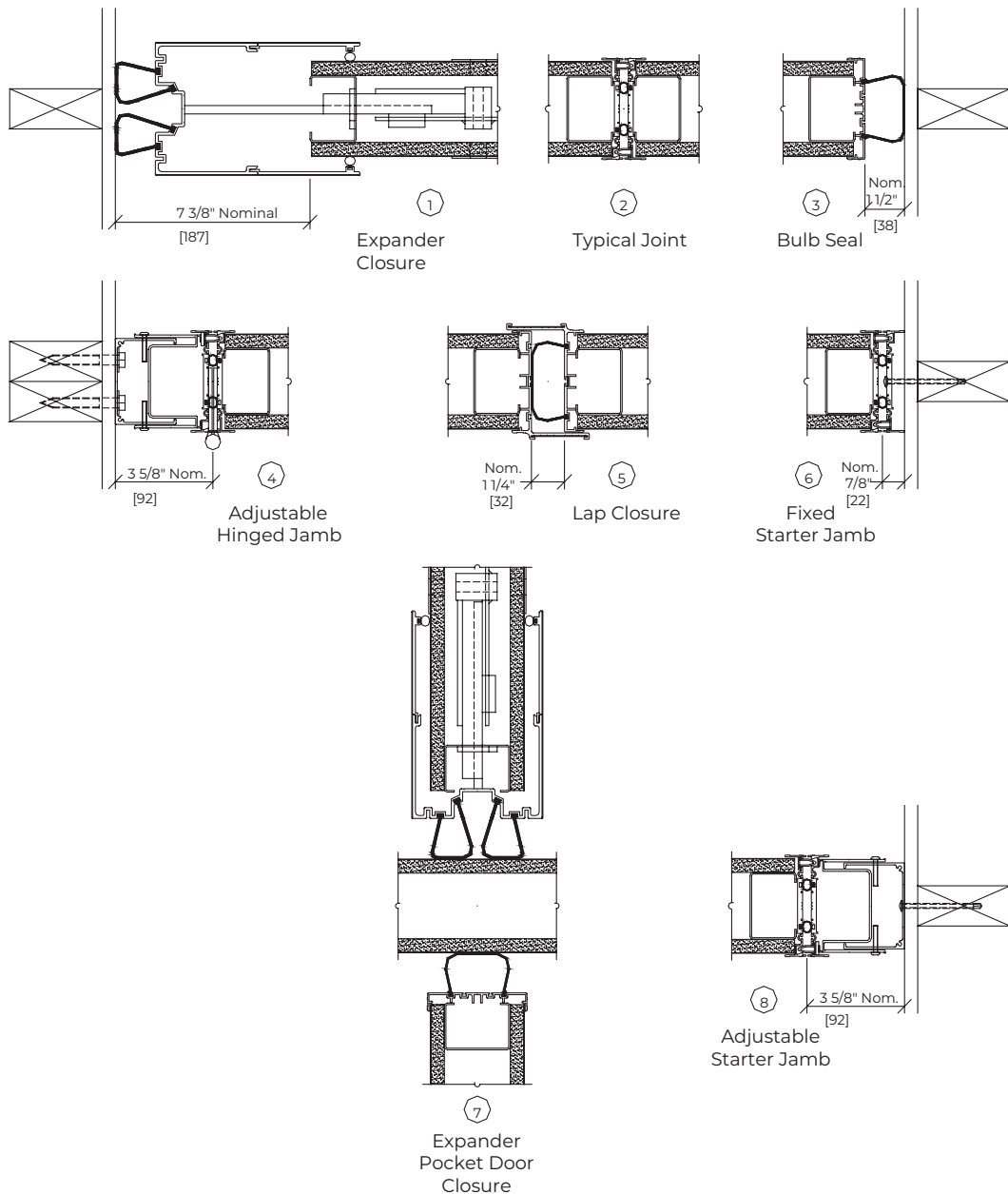



**MODEL 3020** — Individual Multi-Directional Panels

SECTION 10 22 26 [10650] Operable Partitions

SECTION 10 22 39 Folding Panel Partitions

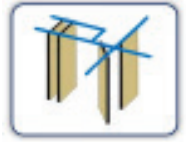

**VERTICAL DETAILS**

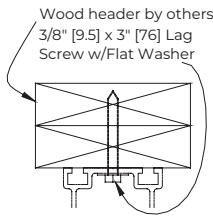

Direct Mount

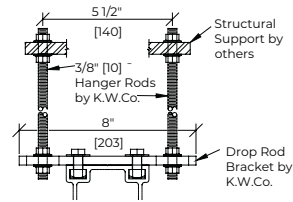

Drop Rod Mount

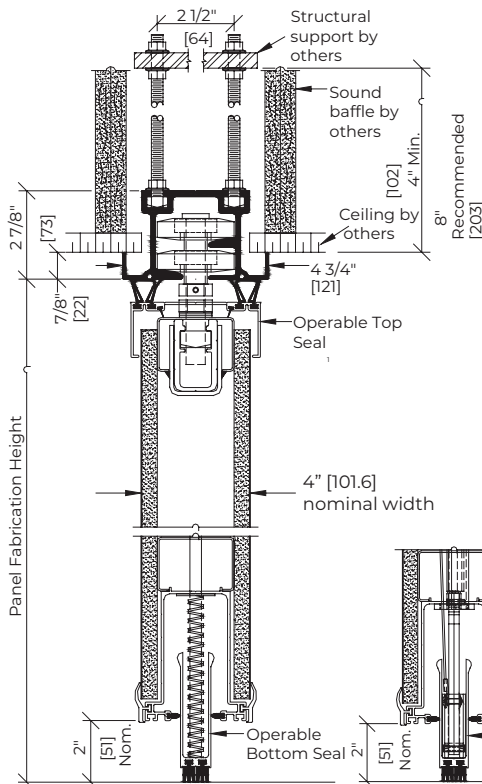

**425 Multi-Directional Aluminum Track and Carrier**

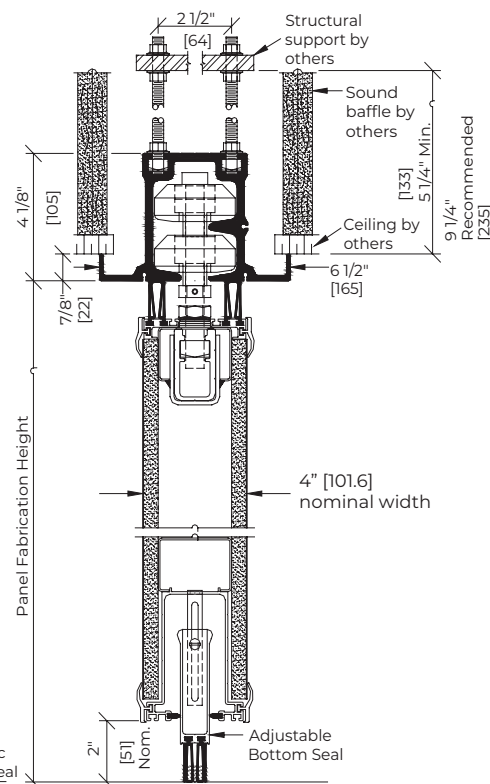

**850 Multi-Directional Aluminum Track and Carrier**

**Notes:**

1. Operable top seal requires standard operable bottom seal.
2. Automatic bottom seal is not available with final closure panel(s).



**MODEL 3020 — Individual Multi-Directional Panels**

SECTION 10 22 26 [10650] Operable Partitions  
SECTION 10 22 39 Folding Panel Partitions

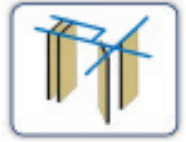

**TRACK OPTIONS**

**Aluminum Track Systems**

Direct attach hanger rods to square nut raceway, **or** alternate attach with hanger brackets

Configuration Application

HP = Hinged Paired Panels  
CD = Individual Panels Curve & Diverter  
MD = Individual Panels Multi-Directional  
CH = Continuously-Hinged Electric Panels

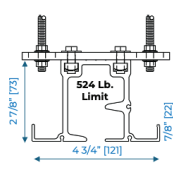

**Type 425**  
MD

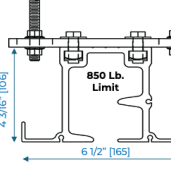

**Type 850**  
MD

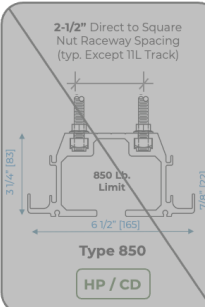

**Type 850**  
HP / CD

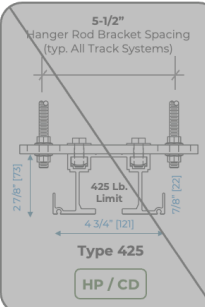

**Type 425**  
HP / CD

N.T.S.

**Steel Track & Aluminum with Steel Tread Track Systems**

Direct attach hanger rods to square nut raceway, **or** alternate attach with hanger brackets

(typ. Except Type 11L Track)

Configuration Application

HP = Hinged Paired Panels  
CD = Individual Panels Curve & Diverter  
MD = Individual Panels Multi-Directional  
CH = Continuously-Hinged Electric Panels

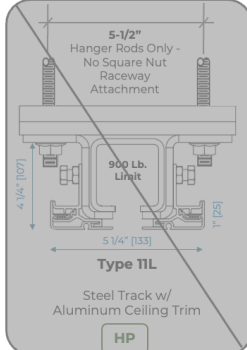

**Type 11L**  
HP

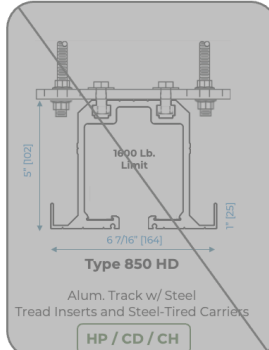

**Type 850 HD**  
HP / CD / CH

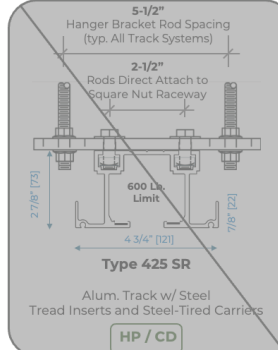

**Type 425 SR**  
HP / CD

N.T.S.

- STC OPTIONS
- PANEL CONSTRUCTION
- PANEL WEIGHTS
- FRAME THICKNESS
- OPENING SIZE LIMITS

**Model 3020 – Individual Multi-Directional Panels**



STC Rating	[S] Steel Skin or [A] Acoustic Substrate	Panel Weight lbs./ft <sup>2</sup>	Panel Thickness	Maximum Opening Height	Maximum Opening Width
56	S	12.9 [62.9 kg/m <sup>2</sup> ]	4"	30'-2" [4.93m]	Unlimited
52	S	9.5 [46.4 kg/m <sup>2</sup> ]	4"	30'-2" [4.93m]	Unlimited
50	S	9.5 [46.4 kg/m <sup>2</sup> ]	4"	30'-2" [4.32m]	Unlimited
46	S	8.5 [41.5 kg/m <sup>2</sup> ]	4"	30'-2" [4.32m]	Unlimited
43	A	5.9 [28.8 kg/m <sup>2</sup> ]	4"	14'-2" [4.32m]	Unlimited
46	A	6.6 [32.2 kg/m <sup>2</sup> ]	4"	14'-2" [4.32m]	Unlimited
48	A	7.5 [36.6 kg/m <sup>2</sup> ]	4"	14'-2" [4.32m]	Unlimited
50	A	9.0 [43.9 kg/m <sup>2</sup> ]	4"	14'-2" [4.32m]	Unlimited

**Note:** Panel weights are for standard intermediate panel function. Weights may vary due to substrate, panel finish and panel functionality. Add 105 lbs. [47 kg] for ea. pass door panel. Add 6 lbs. [3 kg] per lineal ft. height for each expander panel. Add 3.5 lbs. to 8 lbs. [1.6 kg – 3.6 kg] per lineal foot for track weight.

Finishes requiring acoustic substrate construction: High Pressure Laminate & Wood Veneer.

Please refer to: ASTM E 557 "Standard Guide for the Installation of Operable Partitions", for specifics on structural support deflection; floor flatness; and sound transmission flanking path surrounding construction.



**MODEL 3020 — Individual Multi-Directional Panels**

SECTION 10 22 26 [10650] Operable Partitions

SECTION 10 22 39 Folding Panel Partitions

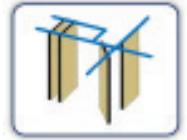

**ELEVATION DETAILS**

KWIK-WALL offers a full complement of accessories for customizing any operable wall system to meet the specific needs of the most demanding project.

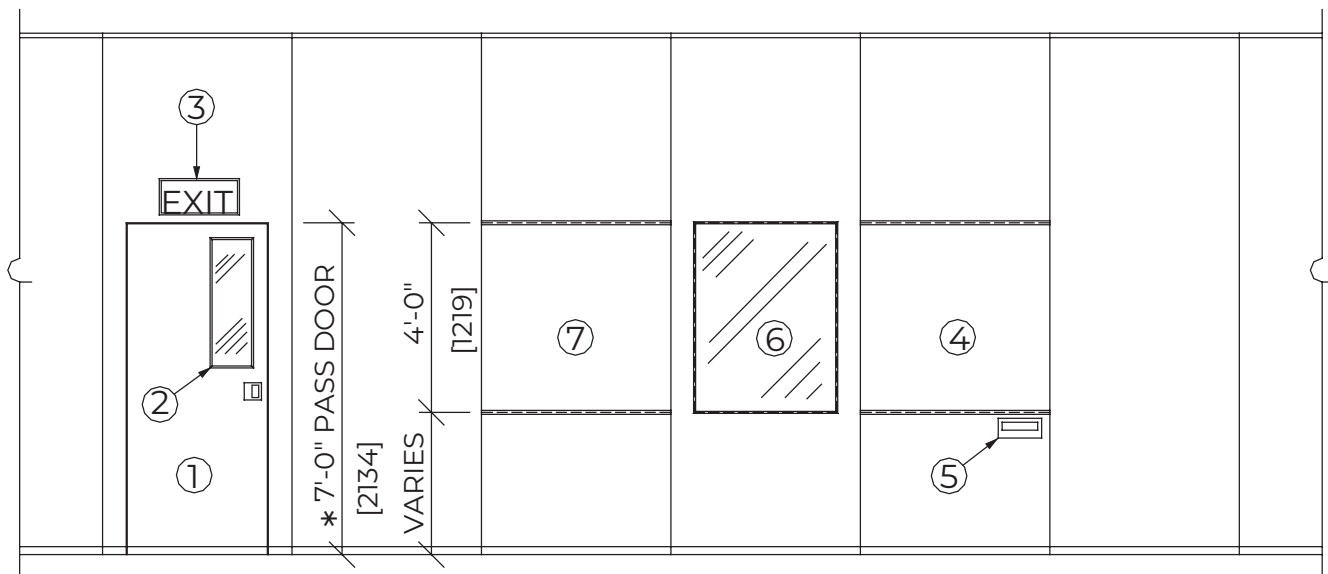

**ACCESSORIES**

- |   |                            |
|---|----------------------------|
| 1. Pass Door (Single shown, double available) | 5. Recessed Eraser Tray    |
| 2. Pass Door Vision Lite                      | 6. Panel Vision Lite       |
| 3. Exit Sign                                  | 7. Tack Surface            |
| 4. Writing Surface                            | 8. Pocket Door (Not shown) |

**Notes:**

- \* 7'-8" (2.34m) minimum panel fabrication height required.
- For complete specifications and details of KWIK-WALL Accessories, please visit our website at [www.kwik-wall.com](http://www.kwik-wall.com).