



3000 SERIES · 2000 SERIES · HUF COR 600 SERIES

MODEL 3030 — Hinged-Paired Panels

SECTION 10 22 26 OPERABLE PARTITIONS
SECTION 10 22 39 FOLDING PANEL PARTITIONS



Overview

Panel Type

- Individual Panels Curve & Diverter
- Individual Panels – Multi Directional
- Hinged-Paired
- Continuously-Hinged

Partition Operation

- Manual
- Electric

Stacking Configurations

- Centerline
- Offset
- Remote
- Bi-Parting

STC Options

A=Acoustic Substrate S=Steel Skin

- 56S 43A
- 52S 46A
- 50S 48A
- 46S 50A

Panel Finishes

- Vinyl High Pressure Laminate
 - Fabric Wood Veneer
 - Carpet Customer Supplied*
 - Digitally Printed Steel Skin
- * Material Subject to Kwik-Wall approval

Vertical Panel Joints

- Trimless
- Capped Trim

Top Seals

- Fixed
- Operable

Bottom Seals

- Fixed Automatic
- Adjustable Fixed Extended
- Operable

Available Options

Storage pocket doors; ADA Pass Doors – (single, double with panic hardware, concealed door closures & exit signs); invisible hinges; dry marker surfaces; insulated glass unit inserts; tack surfaces.

KWIK-WALL's Model 3030 – featuring panels hinged together in groups of two (2), allowing quick and easy set up. With centerline support and operation, hinged-paired panels are ideally suited for straight-run room division applications up to 24'-2" [4928] in height. With STC options from 43-56, 3000 Series Operable Walls offer industry-leading premium sound control.

Model **3030** construction features panels that are 4" [101.6] thick, manufactured of a durable roll-formed steel frame, and standard steel skins for maximum durability and sound control. Optional acoustical glass inserts are available to add daylighting.



3000 Series Panel Weights

STC	lbs/sq ft	kg/m2
56S	12.9 lbs/sq ft	[63 kg/m2]
52S	9.5 lbs/sq ft	[46 kg/m2]
50S	9.5 lbs/sq ft	[46 kg/m2]
46S	8.5 lbs/sq ft	[41 kg/m2]
43A	5.9 lbs/sq ft	[29 kg/m2]
46A	6.6 lbs/sq ft	[32 kg/m2]
48A	7.5 lbs/sq ft	[37 kg/m2]
50A	9.0 lbs/sq ft	[44 kg/m2]



3030

More Information



MODEL 3030 — Hinged-Paired Panels

SECTION 10 22 26 OPERABLE PARTITIONS

SECTION 10 22 39 FOLDING PANEL PARTITIONS



PART 1 – GENERAL

1.01 WORK INCLUDED

- A. Operable Wall System shall be furnished, installed, and serviced by wall manufacturer's authorized distributor, in compliance with the architectural drawings and specifications contained herein.

1.02 RELATED WORK

- A. Structural Support: Structural support system required for suspending the operable wall shall be designed, installed and pre-punched by others, in accordance with ASTM E 557 and manufacturer's shop drawings.
- B. Insulation: Sound insulation and baffles for the plenum area above the track system, under the permanent floor, inside air ducts passing over or around the operable wall, and in permanent walls adjoining the operable wall system shall be by others, in accordance with ASTM E 557.
- C. Opening Preparation: Proper and complete preparation of the operable wall system opening shall be by others in accordance with ASTM E 557 and shall include floor leveling; plumbness of adjoining permanent walls; substrate and/or ceiling tile enclosures for the track system; and the painting and finishing of trim and other materials adjoining the head and jamb areas of the operable wall. Any permanent wall(s) receiving an adjustable or fixed wall jamb will require internal structural blocking to secure the jamb to the permanent wall. Refer to a copy of the shop drawings for additional details.

1.03 SYSTEM DESCRIPTION

- A. The operable wall system shall consist of Hinged Pairs operation, featuring panels hinged together in evenly matched pairs (groups of two (2), unless otherwise specified).
- B. The operable wall system shall consist of acoustically rated panels tested in accordance with ASTM E 90 and ASTM E 413 test procedures, and shall have achieved a STC rating as specified herein (see "Acoustical Performance" article listed under Part 2 – Products).

1.04 QUALITY ASSURANCE

- A. The operable wall shall have been tested in an independent acoustical testing laboratory in accordance with ASTM E 90 and ASTM E 413 test procedures.
- B. The operable wall panel construction and finish materials shall consist of Class A rated materials in accordance with ASTM E 84.
- C. The operable wall shall be installed by the manufacturer's authorized distributor in accordance with ASTM E 557.

1.05 REFERENCES

- A. ASTM E 90: Laboratory Measurement of Airborne-Sound Transmission Loss of Building Partitions.
- B. ASTM E 413: Determination of Sound Transmission Class (STC).
- C. ASTM E 557: Architectural Application and Installation of Operable Partitions.
- D. ASTM E 84: Surface Burning Characteristics of Building Materials.
- E. ASTM A 653: Specification for General Requirements for Steel Sheet, Alloy-Coated (Galvannealed) by the Hot Dip Process.
- F. ASTM C 423: Standard Test Method for Sound Absorption and Sound Absorption Coefficients by the Reverberation Room Method.
- G. CCC-W-408A: Federal Specification which applies to Vinyl Coated Wall Coverings.
- H. CFFA-W-101-D: Chemical Fabrics and Film Association Quality Standard for Vinyl Coated Fabric Wall Coverings.
- I. ATTM E 2190: Certification and testing for Insulated Glass inserts.

1.06 SUBMITTALS

- A. Manufacturer shall provide written technical information and related detail drawings, which demonstrate that the products comply with contract documents for each type of operable partition specified.
- B. Manufacturer shall provide detailed engineering drawings featuring track plan, panel elevation, horizontal and vertical details, and beam punching template as required.
- C. Manufacturer shall provide a written test report of the independent acoustical testing laboratory certifying the attainment of the specified STC rating, upon request.
- D. Manufacturer shall provide written instructions specifying the proper operation and maintenance of the operable wall system.
- E. Manufacturer shall provide a color selector demonstrating the manufacturer's selections of the specified finish material. Samples shall consist of actual swatches of the specified finish material.

1.07 DELIVERY, STORAGE AND HANDLING

- A. Panels shall be individually wrapped in a protective plastic covering to keep panels clean during delivery, storage and handling.
- B. Panels shall be stored on edge and above the floor on cushioned blocking in a dry and ventilated area, protected from humidity and temperature extremes.



MODEL 3030 — Hinged-Paired Panels

SECTION 10 22 26 OPERABLE PARTITIONS

SECTION 10 22 39 FOLDING PANEL PARTITIONS



1.08 SEQUENCING / SCHEDULING

- A. Beam Punching: Manufacturer shall provide a beam punching template drawing detailing the anchor locations for the suspended track system (as required for Drop Rod Mounting), as required for the fabrication and installation of structural overhead support by others.
- B. Track Installation: Scheduling of operable wall track installation shall occur after structural overhead support has been properly and completely fabricated and installed by others.
- C. Panel Installation: Operable wall panel installation shall occur after fixed wall substrate construction is properly and completely installed by others, as required to protect panels from ongoing adjacent construction.

1.09 WARRANTY

Manufacturer shall warrant each operable wall panel and its component parts to be free from defects in material and workmanship for a period of ten (10) years from the date of delivery to the original purchaser, when installed by an authorized KWIK-WALL distributor. KWIK-WALL also warrants the fixed top seals, track, carriers, and its component parts to be free from defects in material and workmanship for a period of ten (10) years. (Contact your local KWIK-WALL Distributor or KWIK-WALL Company for complete warranty information.) (Glass is specifically excluded from the warranty.)

PART 2 – PRODUCTS

2.01 ACCEPTABLE MANUFACTURER

- A. Operable walls shall be Series 3000, Model 3030 Hinged Pairs as manufactured by KWIK-WALL Company.

2.02 PANEL CONSTRUCTION

- A. Panel Dimensions: Standard panel dimension shall be a nominal 4" [101.6] thick.
- B. Panel Frame: Steel frame shall be 16-gauge galvanized steel, horizontal top cross member shall be a minimum 12-gauge galvanized steel that meets or exceeds ASTM A 653 requirements. Frame shall be all-welded construction with steel corner supports and cross-bracing reinforcement. Panel frame shall be Class A-rated, fire-retardant, non-combustible, and non-corrosive in accordance with ASTM E 84.
- C. Panel Skins: Panel skins shall be Class A rated (except Wood Veneer and High-Pressure Laminate) in accordance with ASTM E 84. Panel skin material shall consist of (select):
 1. Steel Skins: consisting of minimum 22-gauge tension-lev- eled galvanized steel, pressure laminated to a structural acoustical backer and mechanically joined to the steel frame to form a rigid, unitized and structural panel.

2. Acoustical Substrate: consisting of structural acoustical substrate pressure-laminated to both sides of the steel frame to form a rigid, unitized, and structural panel.
 3. Wood Veneer: consisting of particle board core covered with wood veneer and pressure laminated to both sides of the steel frame to form a rigid, unitized, and structural panel.
 4. High-Pressure Laminate: consisting of gypsum board core covered with general-purpose plastic laminate and Phenolic backer sheet, which is pressure-laminated to both sides of the steel frame to form a rigid, unitized, and structural panel.
- D. Optional Glass: Opening cut out in panel shall be glazed with insulated glass that is manufactured in accordance with ASTM E 2190. Glass type shall be an acoustical insulated glass unit. Glass shall be retained in opening cut out using an aluminum extrusion.
 - E. Panel Hinges: Panel hinges shall be (select)
 1. Architectural grade, full-leaf butt hinges.
 2. Concealed hinges
 - F. Panel Weight: Maximum panel weight shall be 5.9 – 12.9 lb./ ft.2 (29 – 63 kg/m²) depending on STC rating, size, and options selected.

2.03 OPERATION

- A. Operation shall be Hinged Pairs, consisting of panels hinged together in groups of two (2), unless otherwise specified. Panels shall be top supported by one (1) carrier in each panel.

2.04 STACK ARRANGEMENTS

- A. Stack Type: Panel storage configuration shall be Center Stack, consisting of panels stacked on the centerline to the wall's installed position.
- B. Stack Quantity: Panels shall be stored at (select):
 1. One End: on one end of the wall run.
 2. Both Ends: on both ends of the wall run.

2.05 FINISHES

- A. Finish Material Type: Panel finish material shall be Class A (except wood veneer and high-pressure laminate) rated in accordance with ASTM E 84, consisting of (select):
 1. Vinyl: consisting of Type II, reinforced vinyl weighing 21 oz./lin. yd. (651 g/lin. m). Vinyl shall meet or exceed CCC-W-408A and CFFA-W-101-D quality standards.
 2. Fabric: consisting of fade and tear resistant fabric that resists water-based stains weighing 13 oz./lin. yd. (403 g/ lin. m).



MODEL 3030 — Hinged-Paired Panels

SECTION 10 22 26 OPERABLE PARTITIONS

SECTION 10 22 39 FOLDING PANEL PARTITIONS



3. Carpet: consisting of acoustically absorbent, non-woven needle punch fibers fused to prevent fraying and unraveling of material weighing 28.5 oz./lin. yd. (884 g/lin. m). Basics Carpet shall achieve a minimum NRC (Noise Reduction Coefficient) rating of .20 (applied over gypsum substrate) in accordance with ASTM C 423.
 4. Upgrade Carpet: consisting of acoustically absorbent, non-woven needle punch fibers fused to prevent fraying and unraveling of material weighing 23 oz./lin. yd. (713 g/lin. m). Upgrade Carpet shall achieve a minimum NRC (Noise Reduction Coefficient) rating of .20 (applied over gypsum substrate) in accordance with ASTM C 423.
 5. Wood Veneer: consisting of unfinished flat cut wood veneer laminated to 1/2" [12.7] thick particle board core. Veneer shall be book / running matched within a panel, and edge-banded if Trimless astragals are specified. (Notes: Optional Class "A" rated particle board is available. Acoustical substrate STC ratings apply for Wood Veneer panel construction.)
 6. High-Pressure Laminate: consisting of gypsum board core covered with general-purpose plastic laminate and Phenolic backer sheet, which is pressure laminated to both sides of the steel frame to form a rigid, unitized, and structural panel.
(Note: Acoustical substrate STC ratings apply for High Pressure Laminate panel construction.)
 7. Digitally Printed Steel Skins: Seven-ply construction comprised of melted, rolled, coated, or printed layers.
 8. Optional Unfinished: consisting of panels with exposed acoustical substrate or steel skins for field-applied wall covering or painting.
- B. Finish Material Supplier: Finish material shall be (select):
1. Factory Supplied: from manufacturer's standard selection of finish materials, as specified.
 2. Customer Supplied: from customer's selection of finish material, by others, and as approved by KWIK-WALL Company.
- C. Finish Material Application: Finish material shall be (select):
1. Factory Applied: by operable wall manufacturer. Customer-supplied finish material samples must be submitted to the manufacturer for testing and approval prior to acceptance and application.
 2. Field Applied: by others.

2.06 PERIMETER TRIM AND SEALS

- A. Vertical Trim and Seals: Panels shall have vertical astragals containing flexible vinyl seals and incorporate reversible tongue-and-groove-type configurations for positive interlocking with adjacent panels. Vertical astragal type shall be (select):

1. Trimless Astragal: consisting of an aluminum extrusion with tongue-and-groove-type vertical astragals. Vertical trim shall not be permitted on the panel faces, resulting in a minimal groove appearance between adjacent panels.
 2. Cap-type Astragal: consisting of an aluminum extrusion with tongue-and-groove-type vertical astragals for encapsulating and protecting the finish material and substrate along the vertical edge of the panel.
- B. Horizontal Top Trim and Seals: Top seals shall consist of flexible vinyl sweep seals installed on both sides of the panel. The seals shall consist of a compressed bulb between two (2) fingers of vinyl. Top seal type shall be (select):
1. Fixed Top Seals: consisting of continuous-contact flexible vinyl sealing against the bottom flange of the overhead track.
 2. Operable Top Seals: consisting of an edge-activated seal using a removable wrench as supplied by manufacturer. Top seals shall provide a maximum 1/2" [13] of travel. (Note: Available only with Standard Operable Bottom Seals.)
- C. Horizontal Bottom Trim and Seals: Bottom seals shall consist of multiple fingers of flexible vinyl for positive contact and sealing with various floor surfaces. Bottom seal type shall be (select):
1. Operable Bottom Seals: consisting of an edge-activated seal using a removable wrench as supplied by manufacturer. Bottom seals shall provide 2" [50.8] of nominal travel.
 2. Adjustable Bottom Seals: consisting of field-adjustable, continuous-contact vinyl sweep seals with 2" [50.8] nominal height with 3/4" [19] of nominal adjustment.
 3. Automatic Bottom Seals: consisting of self-activated seals providing 2" [50.8] of nominal travel.
- D. Horizontal and Vertical Panel Trim: All exposed panel trim and hinges shall be of one (1) similar color, as selected from manufacturer's standard colors.

2.07 CLOSURE SYSTEMS

- A. Initial Closure System: The lead panel (the first panel exiting the stack) shall form a seal vertically against a rigid wall surface, as accomplished by a (select):
1. Bulb Seal: consisting of continuous-contact, flexible vinyl bulb seal(s) installed along the vertical edge of the lead panel for positive compression against a rigid wall surface.



MODEL 3030 — Hinged-Paired Panels

SECTION 10 22 26 OPERABLE PARTITIONS

SECTION 10 22 39 FOLDING PANEL PARTITIONS



2. Fixed Starter Jamb: consisting of an aluminum extrusion, which is permanently mounted to a structural wall surface. The Fixed Starter Jamb shall incorporate a tongue-and-groove-type vertical astragal for positive interlocking with the lead panel.
3. Adjustable Starter Jamb: consisting of an aluminum extrusion which is permanently mounted to a structural wall surface and is field-adjustable to compensate for out-of-plumb conditions of the fixed wall. The Adjustable Starter Jamb shall incorporate a tongue-and-groove-type vertical astragal for positive interlocking with the lead panel.
- B. Final Closure System: The final closure panel (the last panel exiting the stack) shall form a seal vertically against a rigid wall surface. The type of final closure panel shall be (select):
 1. Expander Panel Closure: consisting of an expander mechanism with a nominal 5" [127] of travel, activated from the face of the panel using a removable wrench as supplied by manufacturer. The Expander Panel shall be equipped with an adjustable bottom seal (standard) or (optional) operable bottom seal, and a flush pull handle.
 2. Hinged Panel(s) Closure: consisting of a half panel hinged permanently and directly to a structural wall surface. The Hinged Panel(s) shall be equipped with an adjustable bottom seal, a lap-type extrusion for sealing against its adjacent panel (standard) or (optional) expander mechanism with a nominal 5" [127] of travel, activated from the face of the panel using a removable wrench, and a flush pull handle on each side of the panel.
 3. Communicating Panel Closure: consisting of a full-sized panel hinged permanently and directly to a structural wall surface. The Communicating Panel shall function as a full height pass door (maximum panel size: 3'-0" (.91 m) wide x 10'-2" (3.10 m) high), with an adjustable bottom seal, a lap-type extrusion for sealing against its adjacent panel, and a flush pull handle on each side of the panel.
 4. Lap Closure: consisting of a pair of panels equipped with bulb seals for sealing against a rigid wall surface on one side, and a lap-type extrusion that overlaps with the adjacent panel on the opposite side. The Lap Closure panel shall be equipped with adjustable bottom seals, and a flush pull handle.
 5. Single Panel Expander Closure: consisting of an expander mechanism with a nominal 5" [127] of travel, activated from the face of the panel using a removable wrench. The Single Panel Expander shall be capable of rotating 360o and shall be equipped with an adjustable bottom seal or operable bottom seal, and a flush pull handle.

6. Optional Pocket Door(s): (see "Series 3000 Pocket Door" technical data sheet for complete details and specifications).
Note: Optional Automatic Bottom Seal is not available in conjunction with Final Closure panel(s).

2.08 ACOUSTICAL PERFORMANCE

- A. Certification: The operable wall shall have been tested in an independent acoustical testing laboratory in accordance with ASTM E 90 and ASTM E 413 test procedures.
- B. STC Rating: The operable wall acoustical performance rating shall be based on (select):
 1. Steel Skins: 46 STC, 50 STC, 52 STC, 56 STC.
Note: Not available with optional Wood Veneer or High-Pressure Laminate.)
 2. Acoustical Substrate: with optional ratings of 43 STC, 46 STC, 48 STC, or 50 STC.

2.09 PANEL ACCESSORIES

- A. Accessories including Pass Doors; Single or Double, Keyed Cylinder Locks, Concealed Door Closures, Room Viewers, Exit Signs, Dry Marker Writing Surfaces, Recessed Eraser Trays, Vision Lites, Tack Surfaces and Pocket Doors shall be compatible with other accessories and options, furnished and installed by the operable wall manufacturer as noted on submitted shop drawings.

2.10 TRACK SYSTEMS

- A. Track Type: The operable wall track system shall be (select):
 1. Hinged Pairs Aluminum Track: extruded from structural aluminum alloy, which prohibits deterioration caused by rust or corrosion. The aluminum track shall have a durable anodized clear satin finish, which resists color fading and flaking. The track shall utilize grooves and interlocking steel pins for positive alignment of adjacent track sections. The track joints shall be reinforced overhead by a heavy-duty steel bracket made of hot-rolled, 3/8" [10] thick plate steel. Aluminum track shall include an integral nut slot to accept a hardened steel square nut to facilitate attachment of each steel all-rod and splice brackets to the overhead structural support.
 2. Hinged Pairs Steel Track: For panels up to 900lbs [408kg]. Track shall be of 3/16" [5] formed black painted steel connected to the structural support by pairs of 3/8" threaded steel hanger rods. Track trim shall be clear anodized aluminum. Carriers to have four steel wheels with precision-ground radial bearings. Minimum dimension from the ceiling to the structure is 8" [203].
- B. Track Size: The track size shall be:



MODEL 3030 — Hinged-Paired Panels

SECTION 10 22 26 OPERABLE PARTITIONS

SECTION 10 22 39 FOLDING PANEL PARTITIONS



1. Type 425 Hinged Pairs Aluminum Track: certified to be capable of supporting up to 525 lb. (238 kg) of total live load weight per panel.
2. Type 425 Steel Raceway Hinged Pairs Aluminum Track: certified to be capable of supporting up to 525 lb. (238 kg) of total live load weight per panel.
3. Type 850 Hinged Pairs Aluminum Track: certified to be capable of supporting up to 850 lb. (386 kg) of total live load weight per panel.
4. Type 11L Hinged Pairs Steel Track: certified to be capable of supporting up to 900 lb. (408 kg) of total live load weight per panel.

2.11 CARRIER SYSTEMS

- A. Carrier Type: Each Hinged Pair panel shall be top supported by one (1) carrier utilizing a 5/8" [16] diameter pendant bolt. The carrier type shall be (select):
 1. Type 425 Standard Polymer-Tire Carrier: consisting of four (4) permanently lubricated, precision ball bearing steel wheels with high-strength polymer tires, as required for smooth and quiet operation.
 2. Type 425 Steel Raceway, Steel-Tire Carrier: consisting of four (4) permanently lubricated, precision ball bearing steel wheels with high-strength steel tires, as required for smooth and quiet operation.
 3. Type 850 Polymer Tire Carrier: consisting of four (4) permanently lubricated, precision ball bearing steel wheels with high-strength polymer tires, as required for smooth and quiet operation.
 4. Type 11L Steel Wheel Carrier: consisting of four (4) permanently lubricated, precision-ground ball-bearing polished steel wheels, as required for ease of panel movement.
- B. Carrier Size: The carrier size shall be:
 1. Type 425 Hinged Pairs Polymer Tire Carrier: certified to be capable of supporting up to 525 lb. (238 kg) of total live load weight per panel.
 2. Type 425 Steel Raceway, Hinged Pairs Steel Tire Carrier: certified to be capable of supporting up to 600 lb. (272 kg) of total live load weight per panel.
 3. Type 850 Hinged Pairs Polymer Tire Carrier: certified to be capable of supporting up to 850 lb. (386 kg) of total live load weight per panel.
 4. Type 11L Hinged Pairs Steel Wheel Carrier: certified to be capable of supporting up to 900 lb. (408 kg) of total live load weight per panel.

2.12 SUSPENSION SYSTEMS

- A. Mounting Systems: The track shall be supported by (select):
 1. Drop Rod Mount: consisting of adjustable rods of grade 2, 3/8" [10] diameter threaded steel all-rod provided with 3/8" [10] serrated steel nuts.
 2. Direct Mount: consisting of 3/8" [10] x 3" [76] lag screws for attachment to an overhead structural (wood) support. (Direct mount track installations should not exceed 425 lbs. (193 kg) of panel weight.)
 3. Drop Rod Bracket Mount: consisting of 3/8" [10] thick steel brackets mounted to top of track and supported with adjustable rods of grade 2, 3/8" [10] diameter threaded steel all-rod provided with 3/8" [10] serrated steel nuts.

PART 3 – EXECUTION

3.01 INSPECTION

- A. Proper and complete preparation of the operable wall system opening shall be by others in accordance with the architectural drawings, manufacturers shop drawings and ASTM E 557. Any deviation of the actual opening from these specifications shall be called to the attention of the architect prior to the installation of the operable wall.
- B. Deficiencies in the operable wall opening shall be corrected by others prior to installation of the operable wall.

3.02 INSTALLATION

- A. The operable wall system shall be installed by manufacturer's authorized distributor.
- B. The operable wall shall be installed in accordance with manufacturer's written instructions, shop drawings, and ASTM E 557 installation guidelines.

3.03 ADJUSTING AND CLEANING

- A. The operable wall panels and track system shall be adjusted and cleaned in accordance with manufacturer's written instructions.

3.04 PROTECTION

- A. The operable wall panels shall be stored in the stacked (retracted) position prior to acceptance by the owner's representative.

3.05 DEMONSTRATION

- A. The operable wall manufacturer's authorized distributor shall demonstrate proper operation and explain proper and necessary maintenance requirements of the operable wall system to the owner's representative.

For additional information contact:



MODEL 3030 — Hinged-Paired Panels
SECTION 10 22 26 OPERABLE PARTITIONS
SECTION 10 22 39 FOLDING PANEL PARTITIONS



KWIK-WALL Company
900 S. Cain St.
Clinton, IL 61727

Phone: 217-522-5553 or 800-280-5945
(United States and Canada only)
Fax: 217-522-1170 or 800-290-5945 (United States and Canada only)
Website: www.kwik-wall.com
Email: info@kwik-wall.com

Note:
Due to ongoing research and development, some variations may occur in product specifications.
06.26



MODEL 3030 — Hinged-Paired Panels
SECTION 10 22 26 OPERABLE PARTITIONS
SECTION 10 22 39 FOLDING PANEL PARTITIONS



STACKING CONFIGURATIONS

Center Stack

Panels are conveniently stored at one or both ends and stacked on-center to the wall's installed position.

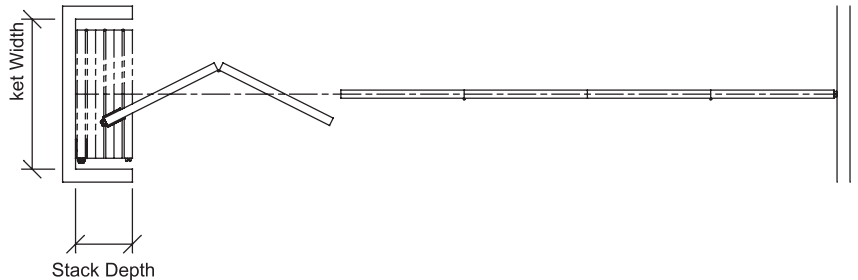

Stack Depth*

The overall depth of the stack area, as required for panel storage, is dictated by the total number of panels in the wall system. Luminous Atlas Panels require an average stack depth of 4 3/8" [111] per panel. To determine the stack depth, calculate as follows:

Number of Panels x 4 3/8" [111]

*Note: Additional stack depth is required for wall systems containing the following type of panels:

- Expander Panel Closure or Pass Door Panel: 3/4" [19]
- Hinged Panel(s) Closure: 4" [102]
- Pocket Door(s): 6" [152]

**Note: For wall systems that include Pocket Doors, please reference KWI-K-WALL's "3000 Series Pocket Door" technical data sheet for pocket layout dimensions and applications.

Pocket Width**

The width of the pocket is determined by the widest panel in the wall run. For specification purposes, assume that the widest panel is 4'-0" (122 cm) maximum. Wall systems that utilize Automatic type bottom seals will require extra pocket width to allow clearance for the actuator that protrudes from the bottom of the lead panel. Pocket width may be calculated as follows:

If Adjustable or Operable Bottom Seals are specified:

Widest Panel + 7" [178]
(allows 3 1/2" [89] for hand clearance on each side)

If Automatic Bottom Seals are specified:

Widest Panel + 8-1/2" [216]
(for actuator clearance on one side)

plus

3 1/2" [89]
(for hand clearance on the other side)



MODEL 3030 — Hinged-Paired Panels
SECTION 10 22 26 OPERABLE PARTITIONS
SECTION 10 22 39 FOLDING PANEL PARTITIONS



FINAL CLOSURES

Communicating Panel Closure

This final closure panel is a full-sized panel (maximum 3'-0" [9] wide x 10'-2" [3.10] high) which is hinged permanently and directly to a structural wall. The communicating panel functions as a full height pass door, incorporates an adjustable bottom seal and includes a flush pull handle on each side of the panel.

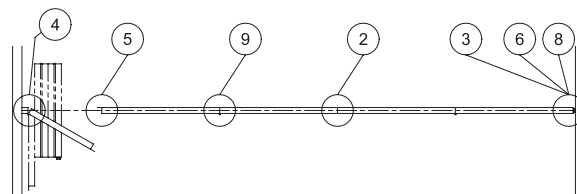

Lap Panel Closure

The final closure is accomplished by two (2) panels equipped with bulb seals for sealing against a rigid wall surface on one (1) side, and a lap-type extrusion that overlaps with the adjacent panel on the opposite side. The lap closure panel is equipped with adjustable bottom seals and includes a flush pull handle.

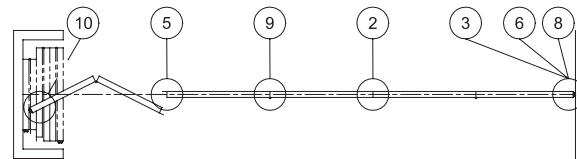

Single Panel Expander Closure

The final closure panel is equipped with an expander mechanism in the same way as the more common expander panel. The single panel expander shall be center hung and capable of rotating 360-and, is equipped with an adjustable bottom seal (standard) or (optional) operable bottom seal and is used specifically with hinged pairs operation, and includes a flush pull handle. (Maximum panel height is 12'-2" [3.71]).

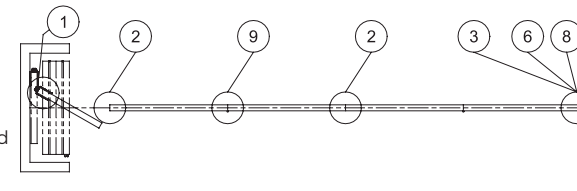

Double Pocket Doors with Expander Closure

The pocket door is equipped with an expander mechanism in the same way as the more common expander panel. Rather than being located on a wall panel, the expander saddle is integrated into a pocket door panel. The saddle expander will be fully retracted with a pair of bulb seals compressed against the last panel exiting the stack. The pocket doors are provided with fixed bottom seals as a factory standard and includes a foot bolt and flush pull handle.

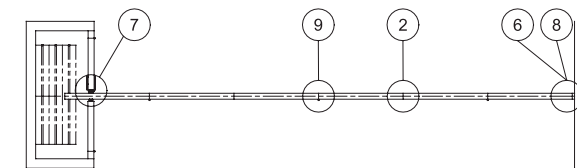



MODEL 3030 — Hinged-Paired Panels
 SECTION 10 22 26 OPERABLE PARTITIONS
 SECTION 10 22 39 FOLDING PANEL PARTITIONS



HORIZONTAL TRIMLESS DETAILS

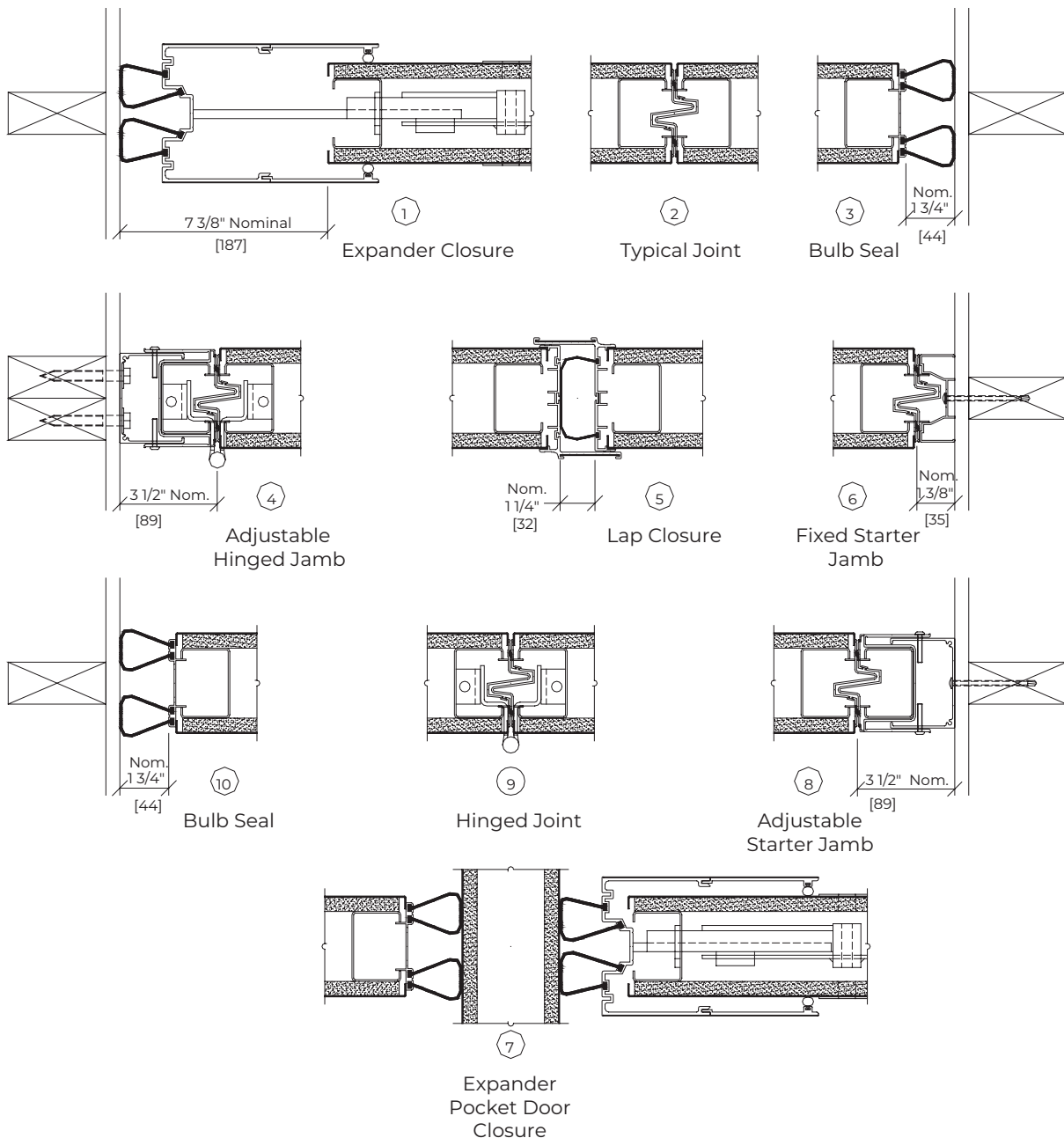



MODEL 3030 — Hinged-Paired Panels
 SECTION 10 22 26 OPERABLE PARTITIONS
 SECTION 10 22 39 FOLDING PANEL PARTITIONS



HORIZONTAL CAP-TYPE DETAILS

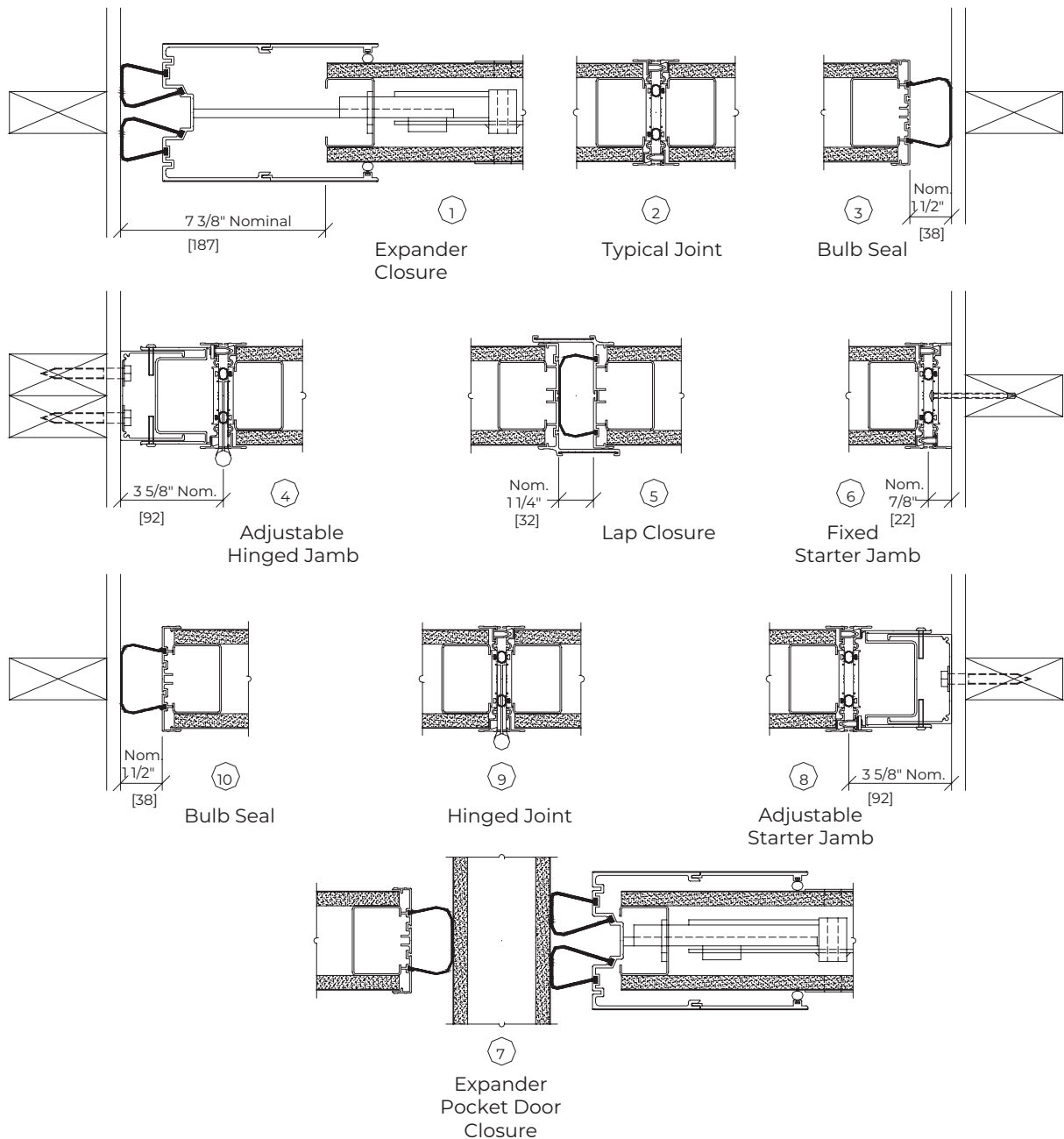



MODEL 3030 — Hinged-Paired Panels
SECTION 10 22 26 OPERABLE PARTITIONS
SECTION 10 22 39 FOLDING PANEL PARTITIONS



VERTICAL DETAILS

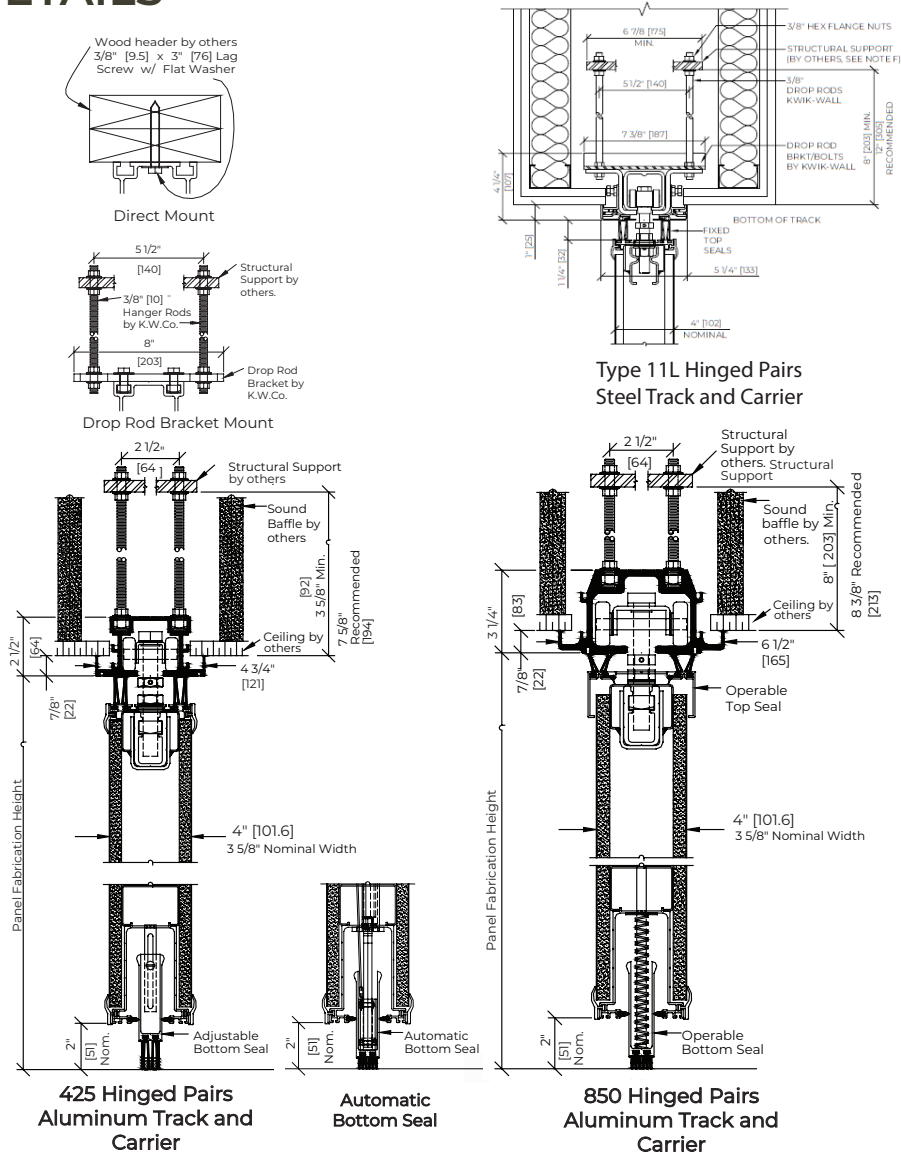

- Notes:**
1. Operable top seal requires standard operable bottom seal.
2. Automatic bottom seal is not available with final closure panel(s).



MODEL 3030 — Hinged-Paired Panels

SECTION 10 22 26 OPERABLE PARTITIONS
SECTION 10 22 39 FOLDING PANEL PARTITIONS



TRACK OPTIONS

Aluminum Track Systems

Direct attach hanger rods to square nut raceway, **or** alternate attach with hanger brackets

Configuration Application

HP = Hinged Paired Panels
CD = Individual Panels Curve & Diverter
MD = Individual Panels Multi-Directional
CH = Continuously-Hinged Electric Panels

N.T.S.

Steel Track & Aluminum with Steel Tread Track Systems

Direct attach hanger rods to square nut raceway, **or** alternate attach with hanger brackets

(typ. Except Type 11L Track)

Configuration Application

HP = Hinged Paired Panels
CD = Individual Panels Curve & Diverter
MD = Individual Panels Multi-Directional
CH = Continuously-Hinged Electric Panels

N.T.S.

- STC OPTIONS
- PANEL CONSTRUCTION
- PANEL WEIGHTS
- FRAME THICKNESS
- OPENING SIZE LIMITS

Model 3030 – Hinged-Paired Panels



STC Rating	[S] Steel Skin or [A] Acoustic Substrate	Panel Weight lbs./ft ²	Panel Thickness	Maximum Opening Height	Maximum Opening Width
56	S	12.9 [62.9 kg/m ²]	4"	30'-2" [4.93m]	Unlimited
52	S	9.5 [46.4 kg/m ²]	4"	30'-2" [4.93m]	Unlimited
50	S	9.5 [46.4 kg/m ²]	4"	30'-2" [4.32m]	Unlimited
46	S	8.5 [41.5 kg/m ²]	4"	30'-2" [4.32m]	Unlimited
43	A	5.9 [28.8 kg/m ²]	4"	14'-2" [4.32m]	Unlimited
46	A	6.6 [32.2 kg/m ²]	4"	14'-2" [4.32m]	Unlimited
48	A	7.5 [36.6 kg/m ²]	4"	14'-2" [4.32m]	Unlimited
50	A	9.0 [43.9 kg/m ²]	4"	14'-2" [4.32m]	Unlimited

Note: Panel weights are for standard intermediate panel function. Weights may vary due to substrate, panel finish and panel functionality. Add 105 lbs. [47 kg] for ea. pass door panel. Add 6 lbs. [3 kg] per lineal ft. height for each expander panel. Add 3.5 lbs. to 8 lbs. [1.6 kg – 3.6 kg] per lineal foot for track weight.

Finishes requiring acoustic substrate construction: High Pressure Laminate & Wood Veneer.

Please refer to: ASTM E 557 "Standard Guide for the Installation of Operable Partitions", for specifics on structural support deflection; floor flatness; and sound transmission flanking path surrounding construction.



MODEL 3030 — Hinged-Paired Panels

SECTION 10 22 26 OPERABLE PARTITIONS
 SECTION 10 22 39 FOLDING PANEL PARTITIONS



ELEVATION DETAILS

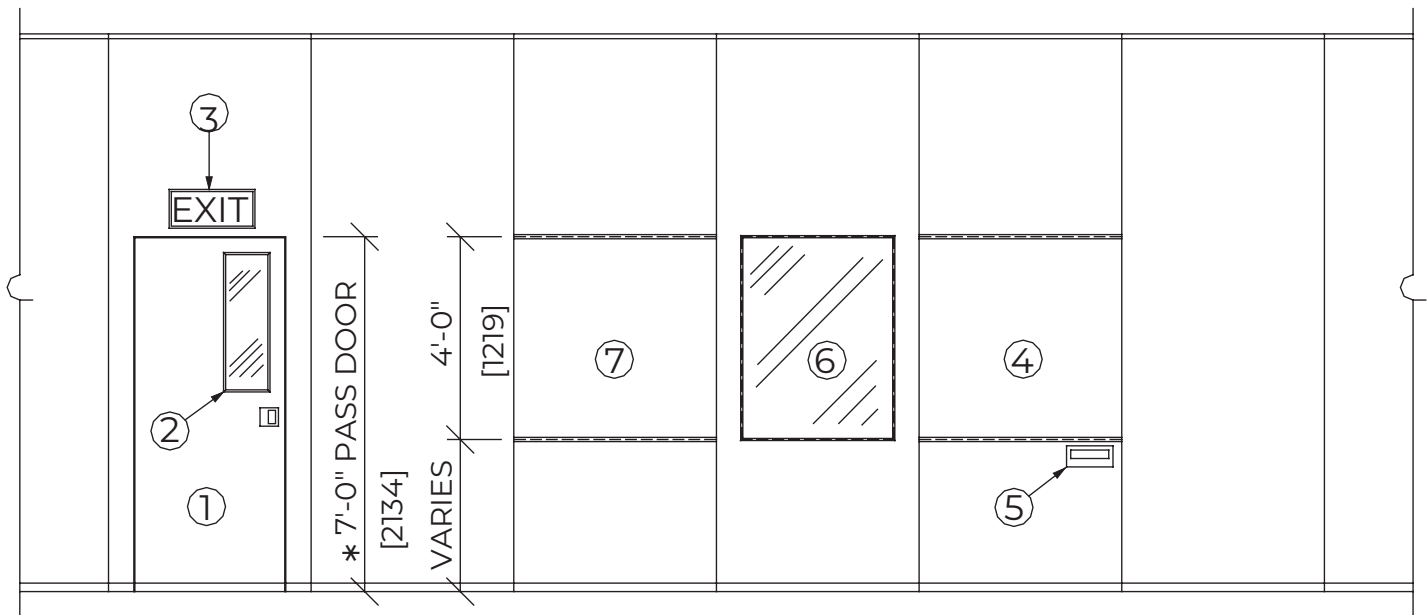

ACCESSORIES

- 1. Pass Door (Single shown, double available)
- 2. Pass Door Vision Lite
- 3. Exit Sign
- 4. Writing Surface
- 5. Recessed Eraser Tray
- 6. Panel Vision Lite
- 7. Tack Surface
- 8. Pocket Door (Not shown)

Notes:

- 1. *7'-8" (2.34m) minimum panel fabrication height required.
- 2. For complete specifications and details of KWIK-WALL Accessories, please visit our website at www.kwik-wall.com.